





SPECIFICATION

**Product Model:
PV101034Y0140X-CO**

DESIGNED	CHECKED	Approved
		

Approval by Customer:

Customer name:

Customer model:

Approved By _____



Revision Record

REV NO.	REV DATE	CONTENTS	Note
V0	2022.06.10	NEW ISSUE	



Table of Contents

List	Description	Page No.
	Cover	1
	Revision Record	2
	Table of Contents	3
1	Scope	4
2	General Information	4
3	External Dimensions	5
4	Interface Description	6
5	Absolute Maximum Ratings	7
6	DC Characteristics	8
7	Timing Characteristics	9
8	Backlight Characteristics	11
9	Optical Characteristics	11
10	Reliability Test Conditions and Methods	14
11	Inspection Standard	15
12	Handling Precautions	19
13	Precaution for Use	20
14	Packing Method	20



1. Scope

This specification defines general provisions as well as inspection standards for TFT module supplied by Kingtech Group Co.,Ltd.

If the event of unforeseen problem or unspecified items may occur, naturally shall negotiate and agree to solution.

2. General Information

ITEM	STANDARD VALUES	UNITS
LCD type	10.1" TFT	--
Dot arrangement	1280×3(RGB)×800	dots
Color filter array	RGB vertical stripe	--
Display mode	Normally Black	-
Viewing Direction	85/85/85/85	--
Module size	233.06(W)×153.7(H)×4.93(T)	mm
Active area	216.96(W)×135.60(H)	mm
Dot pitch	0.1695(W)×0.1695(H)	mm
Interface	4 Lane MIPI Interface	--
Operating temperature	-20 ~ +70	°C
Storage temperature	-30 ~ +80	°C
Weight	450	g

2.1 Touch Panel Characteristics

ITEM	STANDARD VALUES	UNITS
CTP type	Cover Lens + Sensor + FPC	--
CTP Driver IC	ILI2511	--
Transmittance	≥85%	--
The cover hardness	6H	--
CTP Viewing area	217.96(W)×136.6(H)	mm
CTP Interface	I2C/USB	
I2C Address (7 Bits)	0x41	
Operating temperature	-20 ~ +70	°C
Storage temperature	-30 ~ +80	°C



3. External Dimensions

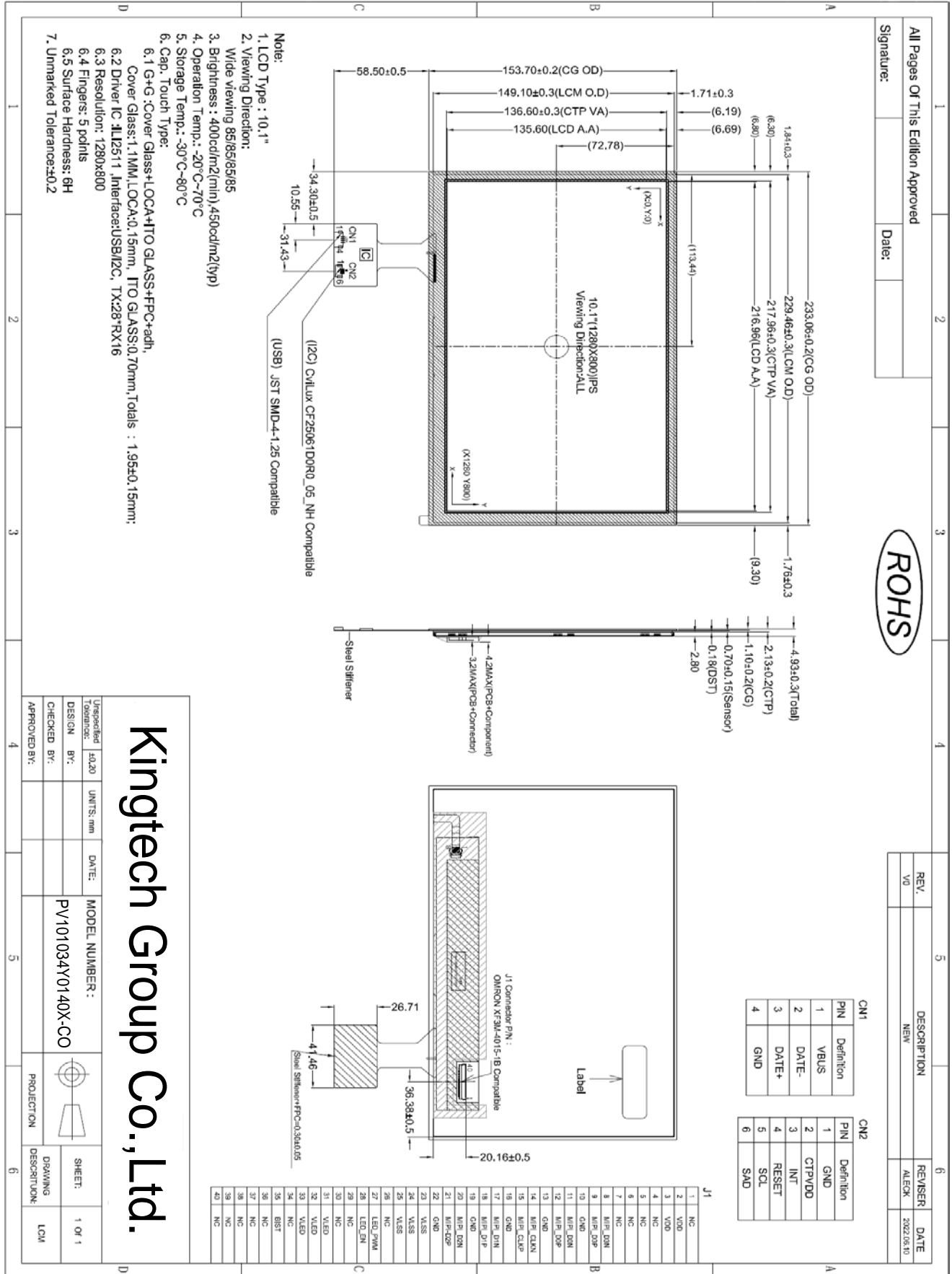

All Pages Of This Edition Approved
 Signature: _____ Date: _____



REV.	DESCRIPTION	REVISOR	DATE
V0	NEW	ALECK	2022.06.10

Kingtech Group Co., Ltd.

Unspecified Tolerance: ±0.20	UNITS: mm	DATE:	MODEL NUMBER:	PROJECTION	SHEET:
DESIGN BY:			PV101034Y0140X-CO		1 OF 1
CHECKED BY:				DRAWING DESCRIPTION:	LCD
APPROVED BY:					



4. Interface Description

4.1 LCM PIN: J1

PIN	PIN NAME	DESCRIPTION	Remark
1	NC	No connection	
2-3	VDD	Power Supply	
4-7	NC	No connection	
8	MIPI_D3N	- MIPI Differential Data Input	
9	MIPI_D3P	+ MIPI Differential Data Input	
10	GND	Ground	
11	MIPI_D0N	- MIPI Differential Data Input	
12	MIPI_D0P	+ MIPI Differential Data Input	
13	GND	Ground	
14	MIPI_CLKN	- MIPI Differential Data Input	
15	MIPI_CLKP	+ MIPI Differential Data Input	
16	GND	Ground	
17	MIPI_D1N	- MIPI Differential Clock Input	
18	MIPI_D1P	+ MIPI Differential Clock Input	
19	GND	Ground	
20	MIPI_D2N	- MIPI Differential Data Input	
21	MIPI_D2P	+ MIPI Differential Data Input	
22	GND	Ground	
23-25	VLSS	Ground	
26	NC	No connection	
27	LED_PWM	CABC controller signal output for backlight	
28	LED_EN	CABC Enable Input	
29	NC	No connection	
30	NC	No connection	
31-33	VLED	Power Supply for LED Backlight Driver	
34	NC	No connection	
35	BIST	No connection	
36	NC	No connection	
37	NC	No connection	
38	NC	No connection	
39	NC	No connection	
40	NC	No connection	



4.2 CTP I2C PIN: CN2

Pin	Pin Name	Description	Remark
1	GND	Ground	
2	CTP_VDD	Power supply: + 3.3V	
3	INT	Output interrupt signal for host controller.	
4	RESET	Input reset signal.	
5	SCL	I2C Clock. (T/P)	
6	SDA	I2C Data. (T/P)	

4.3 CTP USB PIN: CN1

Pin	Pin Name	Description	Remark
1	VBUS	Power supply: + 5V	
2	DATA-	DATA- Differential Data Input.	
3	DATA+	DATA+ Differential Data Input.	
4	GND	Ground	

5. Absolute Maximum Ratings

Item	Symbol	Min.	Max.	Unit	Remark
Digital Supply Voltage	VDD	-0.3	4.0	V	
VIN Voltage	VLED	-0.3	27	V	
Operating Temperature	T _{OP}	-20	70	°C	
Storage Temperature	T _{ST}	-30	80	°C	

6. DC Characteristics



6.1 LCM Parameters

Item	Symbol	Min.	Typ.	Max.	Unit	Remark
Digital Supply Voltage	VDD	2.75	3.3	3.6	V	-
Backlight Power Voltage	VLED	8	12	15	V	
Digital Supply Current	IDD	-	200	300	mA	VDD=3.3V
Backlight Power Current	I-VLED	-	220	350	mA	VLED=12V
Input logic high voltage	V _{IH}	0.8*VDD	-	VDD	V	-
Input logic low voltage	V _{IL}	GND	-	0.2*VDD	V	
LED_EN Control Level	V _{IH}	1.9		VLED	V	
	V _{IL}	GND		0.8	V	
LED_PWM Control Level	V _{IH}	1.9		VLED	V	
	V _{IL}	GND		0.8	V	
PWM Frequency	LED_PWM	100		30000	Hz	

6.2 CTP Parameters

Item	Symbol	Min.	Typ.	Max.	Unit	Remark
Power Voltage	CTP_VDD	3.0	3.3	3.6	V	
	VBUS	4.5	5	5.5	V	
Input logic high voltage	V _{IH}	0.6* CTP_VDD	-	CTP_VDD+0.5	V	
Input logic low voltage	V _{IL}	0	-	0.3* CTP_VDD	V	
Output High Voltage	V _{OH}	0.7* CTP_VDD	-	-	V	
Output Low Voltage	V _{OL}	-	-	0.3* CTP_VDD	V	

7. Timing Characteristics

7.1 Power On and Reset Timing

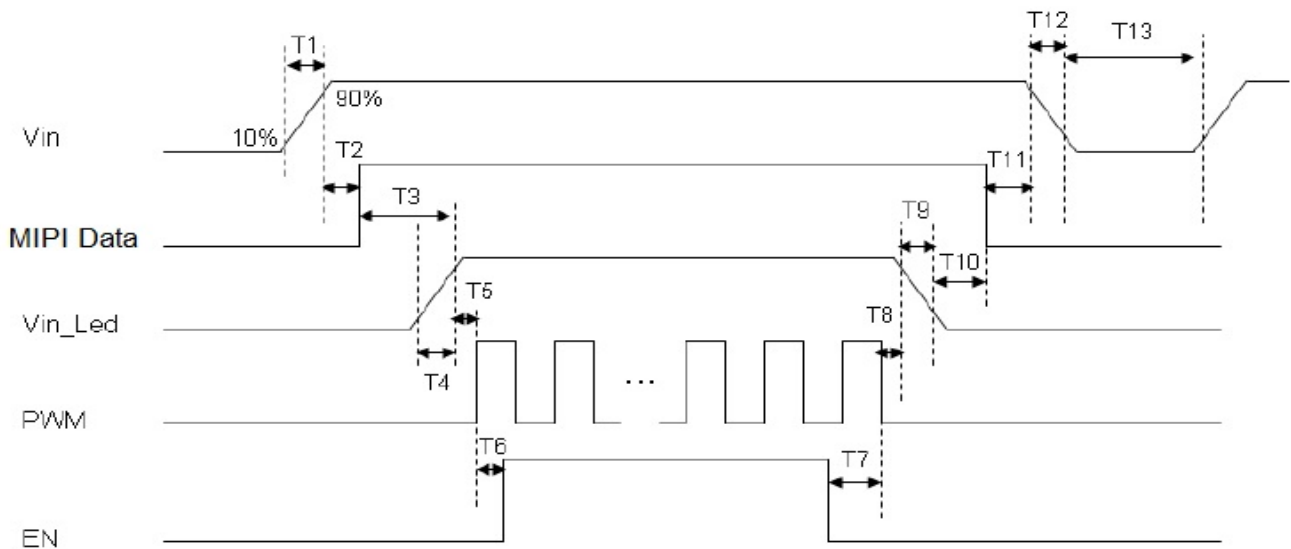

Parameter	Symbol	Min.	Typ	Max.	Unit
Vin rise time	T1	0.5	-	10	ms
Vin good to signal valid	T2	30	-	90	ms
Signal valid to backlight on	T3	200	-	-	ms
Backlight power on time	T4	0.5	-	-	ms
Backlight VDD good to system PWM on	T5	10	-	-	ms
System PWM on to backlight enable on	T6	10	-	-	ms
Backlight enable of to system PWM off	T7	0	-	-	ms
System PWM off to B/L power disable	T8	10	-	-	ms
Backlight power off time	T9	0.5	10	30	ms
Backlight off to signal disable	T10	200	-	-	ms
Signal disable to power down	T11	0	-	50	ms
VIN fall time	T12	0.5	10	30	ms
Power off	T13	500	-	-	ms



7.2 Timing for DSI video mode

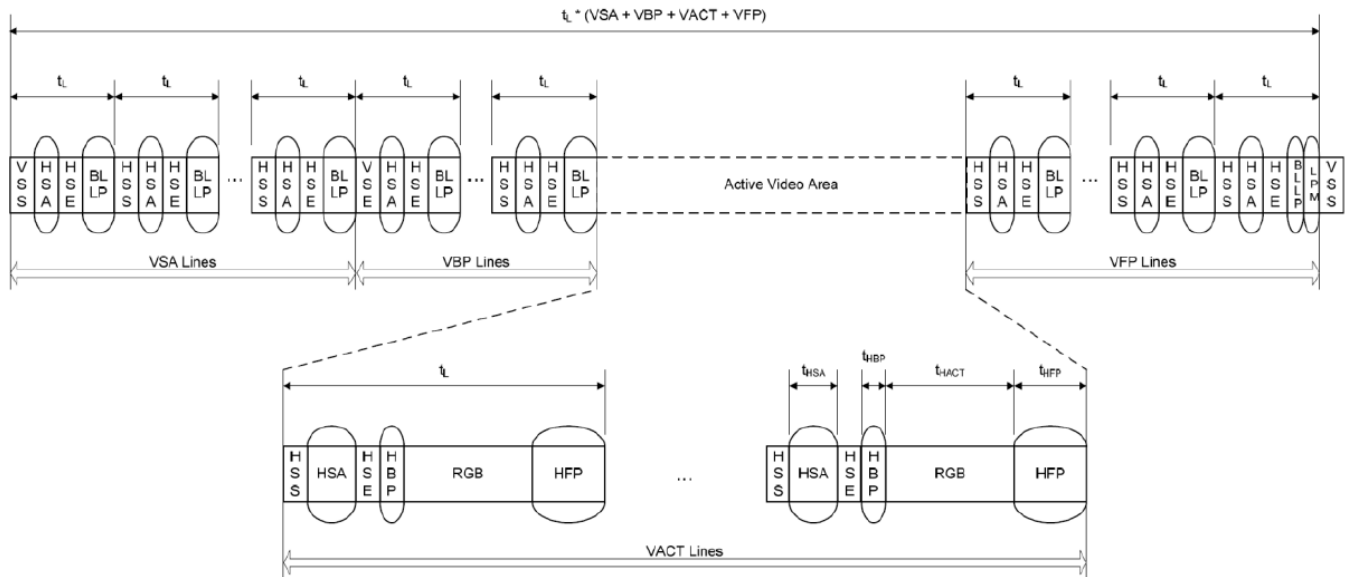

7.3 Interface Timings

Parameter	Symbol	Min.	Typ	Max.	Unit
DCLK frequency @Frame rate=60Hz	F_{DCLK}	66.3	72.4	78.9	MHz
HSYNC period time	T_H	1380	1440	1500	DCLK
Horizontal display area	T_{HD}	1280			DCLK
HSYNC period width	T_{HPW}	2	-	40	DCLK
HSYNC back porch (with pulse width)	T_{HBP}	88	88	88	DCLK
HSYNC front porch	T_{HFP}	12	72	132	DCLK
VSYNC period time	T_V	824	838	872	H
Vertical display area	T_{VD}	800			H
VSYNC period width	T_{VPW}	2	-	20	H
VSYNC back porch (with pulse width)	T_{VBP}	23	23	23	H
VSYNC front porch	T_{VFP}	1	15	49	H



8. Backlight Characteristic

Item	Symbol	MIN	TYP	MAX	UNIT	NOTE
Lifetime		50000	-	-	Hr	
Color	White					
Luminous Intensity for LCM and TP	LED_PWM =100%	400	450	-	cd/m2	
Luminance uniformity		80	-	-	%	

9. Optical Characteristics

Item	Conditions	Min.	Typ.	Max.	Unit	Note	
Viewing Angle (CR>10)	Horizontal	θ_L	-	85	-	degree	(1),(2),(6)
		θ_R	-	85	-		
	Vertical	θ_T	-	85	-		
		θ_B	-	85	-		
Contrast Ratio	Center	800	1000	-	-	(1),(3),(6)	
Response Time	T_R+T_F	-	25	35	ms	(1),(4),(6)	
CF Color Chromaticity (CIE1931)	Red x	Typ. -0.05	0.59	Typ. +0.05	-	(1), (6)	
	Red y		0.34		-		
	Green x		0.35		-		
	Green y		0.59		-		
	Blue x		0.14		-		
	Blue y		0.10		-		
	White x		0.30		-		
	White y		0.33		-		
Color Gamut	CIE 1931	-	53	-	%		

Note (1) Measurement Setup: The LCD module should be stabilized at given temp. 25°C for 15



minutes to avoid abrupt temperature change during measuring. In order to stabilize the luminance, the measurement should be executed after lighting backlight for 15 minutes in a windless room.

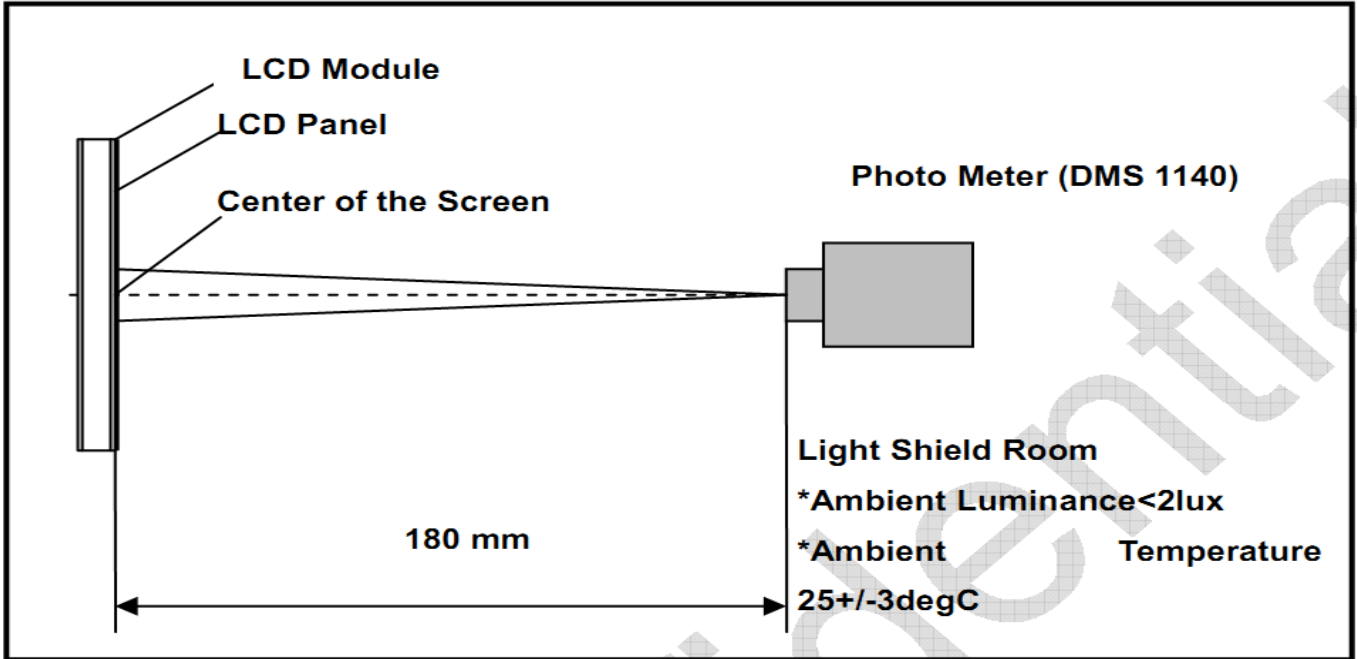

Note (2) Definition of Viewing Angle

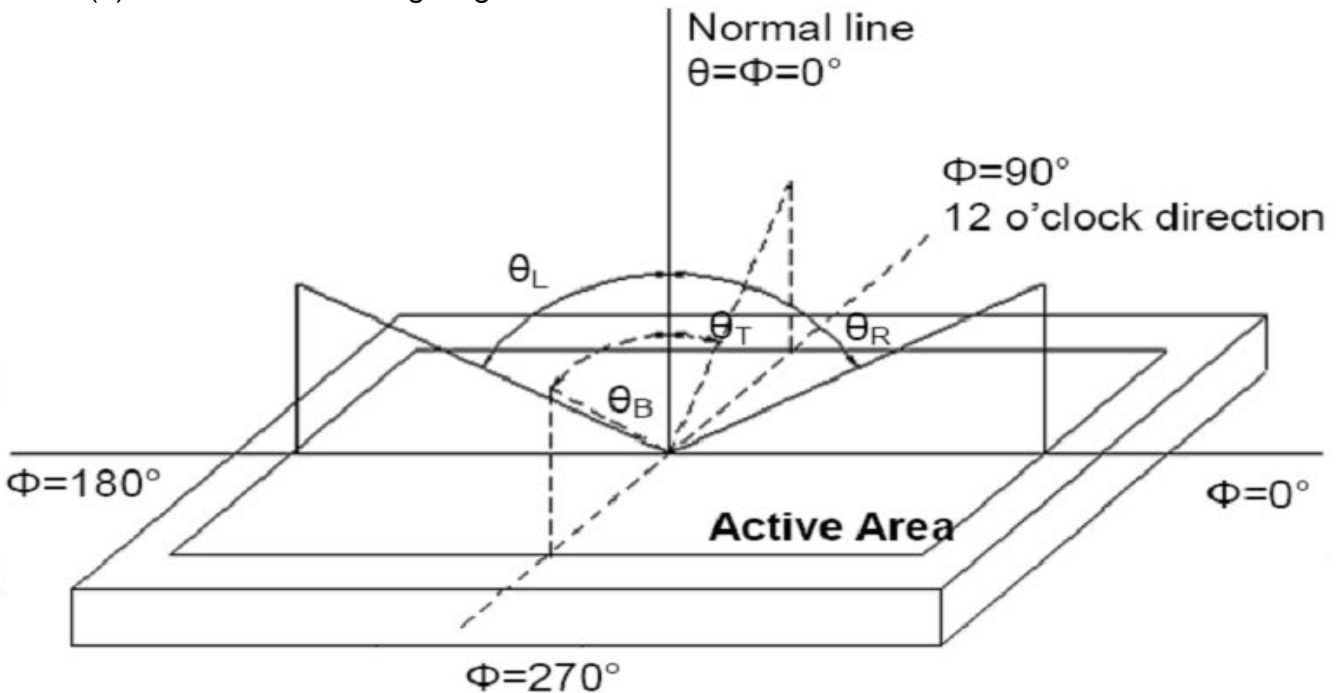

Note (3) Definition of Contrast Ratio (CR)

The contrast ratio can be calculated by the following expression

$$\text{Contrast Ratio (CR)} = L_{63} / L_0$$

L63: Luminance of gray level 63, L0: Luminance of gray level 0

Note (4) Definition of response time

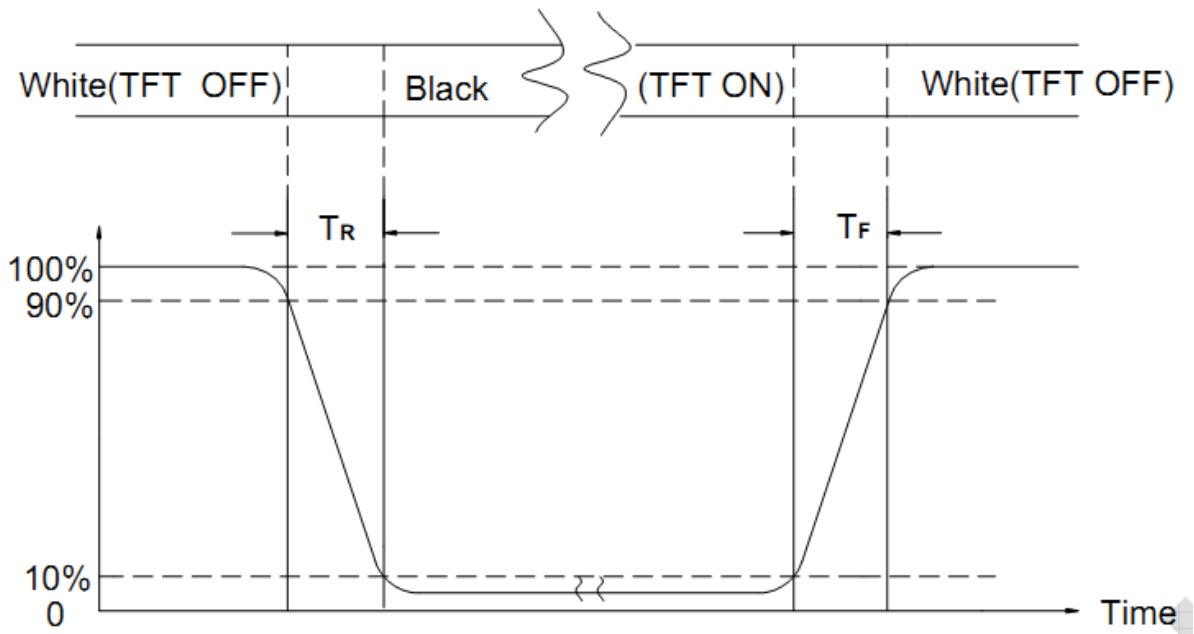

Note (5) Definition of Transmittance (Module is without signal input)

$$\text{Transmittance} = \text{Center Luminance of LCD} / \text{Center Luminance of Back Light} \times 100\%$$

Note (6) Definition of color chromaticity (CIE1931)

Color coordinates measured at the center point of LCD

Note (7) C-light Spectrum Based on VESA-1931

Figure 4 C-Light Spectrum

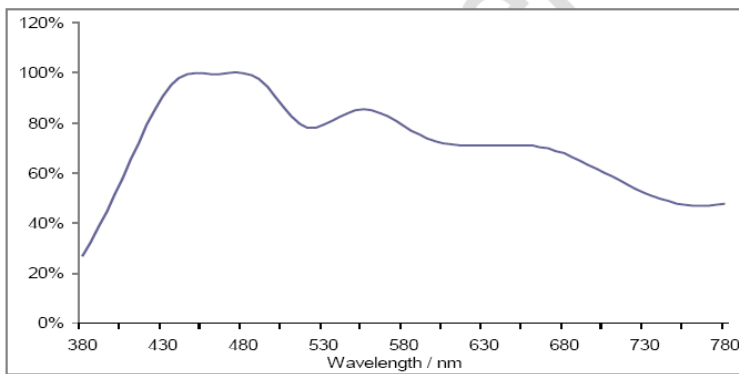

Note (8) The Nomal polarizer type:

SAPO: T4-1025THC(P)/CF; SAPO:T4-1025T(P) /TFT;

Note (9) All optical data based on YX given polarizer & light Source & testing machine in this document.



10. Reliability Test Conditions and Methods

NO.	Test Items	Test Condition											
①	High Temperature Storage	Keep in 80°C±2°Cx240Hrs Surrounding temperature, then storage at normal condition 4hrs.											
②	Low Temperature Storage	Keep in -30°C±2°Cx240Hrs Surrounding temperature, then storage at normal condition 4hrs.											
③	High Temperature Operating Test	70°C±2°Cx240Hrs											
④	Low Temperature Operating Test	-20°C±2°Cx240Hrs											
⑤	High Temperature / High Humidity Storage Test	Keep in 60°C±5°Cx90%RHx240Hrs Surrounding temperature, then storage at normal condition 4hrs.											
⑥	Temperature Cycling Storage Test	<div style="text-align: center;"> $-30^{\circ}\text{C} \xrightarrow{(30\text{mins})} +25^{\circ}\text{C} \xrightarrow{(5\text{mins})} 80^{\circ}\text{C} \xrightarrow{(30\text{mins})} +25^{\circ}\text{C} \xrightarrow{(5\text{mins})}$ ←----- 30 Cycle -----→ </div> Surrounding temperature, then storage at normal condition 4hrs.											
⑦	ESD Test	Air Discharge: Apply 6 KV with 5 times Discharge for each polarity +/-	Contact Discharge: Apply 250 V with 5 times discharge for each polarity +/-										
		1. Temperature ambience : 15°C~35°C 2. Humidity relative : 30%~60% 3. Energy Storage Capacitance (Cs + Cd): 150pF±10% 4. Discharge Resistance (Rd): 330Ω±10% 5. Discharge, mode of operation: Single Discharge (time between successive discharges at least 1 sec) (Tolerance if the output voltage indication : ±5%)											
⑧	Vibration Test (Packaged)	1. Sine wave 10~55 Hz frequency (1 min/sweep) 2. The amplitude of vibration :1.5 mm 3. Each direction (X、Y、Z) duration for 2Hrs											
⑨	Drop Test (Packaged)	<table border="1" style="margin-left: auto; margin-right: auto;"> <thead> <tr> <th>Packing Weight (Kg)</th> <th>Drop Height (cm)</th> </tr> </thead> <tbody> <tr> <td style="text-align: center;">0 ~ 45</td> <td style="text-align: center;">122</td> </tr> <tr> <td style="text-align: center;">45.4 ~ 90.8</td> <td style="text-align: center;">76</td> </tr> <tr> <td style="text-align: center;">90.8 ~ 454</td> <td style="text-align: center;">61</td> </tr> <tr> <td style="text-align: center;">Over 454</td> <td style="text-align: center;">46</td> </tr> </tbody> </table>		Packing Weight (Kg)	Drop Height (cm)	0 ~ 45	122	45.4 ~ 90.8	76	90.8 ~ 454	61	Over 454	46
		Packing Weight (Kg)	Drop Height (cm)										
0 ~ 45	122												
45.4 ~ 90.8	76												
90.8 ~ 454	61												
Over 454	46												
Drop Direction: ※1 corner / 3 edges / 6 sides each 1time													

PS: ①~⑦ test exclude Polaroid;



11. Inspection Standard

11.1. QUALITY :

THE QUALITY OF GOODS SUPPLIED TO PURCHASER SHALL COME UP TO THE FOLLOWING STANDARD.

11.1.1. THE METHOD OF PRESERVING GOODS

AFTER DELIVERY OF GOODS FROM KINGTECH TO PURCHASER. PURCHASER SHALL CONTROL THE LCM AT -10 TO 40 ,AND IT MIGHT BE DESIRABLE TO KEEP AT THE NORMAL ROOM TEMPERATURE AND HUMIDITY UNTIL INCOMING INSPECTION OR THROWING INTO PROCESS LINE.

11.1.2. INCOMING INSPECTION

(A) THE METHOD OF INSPECTION

IF PURCHASER MAKE AN INCOMING INSPECTION , A SAMPLING PLAN SHALL BE APPLIED ON THE CONDITION THAT QUALITY OF ONE DELIVERY SHALL BE REGARDED AS ONE LOT.

(B) THE STANDARD OF QUALITY

ISO-2859-1 (SAME AS MIL-STD-105E) ,LEVEL:II

CLASS	AQL(%)
CRITICAL	0.4 %
MAJOR	0.65 %
MINOR	1.5 %

EVERY ITEM SHALL BE INSPECTED ACCORDING TO THE CLASS.

(C) MEASURE

IF AS THE RESULT OF ABOVE RECEIVING INSPECTION , A LOT OUT IS DISCOVERED. PURCHASER SHALL BE INFORM SELLER OF IT WITHIN SEVEN DAYS. BUT FIRST SHIPMENT WITHIN FOURTEEN DAYS.

11.1.3. WARRANTY POLICY

KINGTECH WILL PROVIDE ONE -YEAR WARRANTY FOR THE PRODUCTS ONLY IF UNDER SPECIFICATION OPERATING CONDITIONS. KINGTECH WILL REPLACE NEW PRODUCTS FOR THESE DEFECT PRODUCTS WHICH UNDER WARRANTY PERIOD AND BELONG TO THE RESPONSIBILITY OF KINGTECH.

11.2. CHECKING CONDITION

11.2.1.CHECKING DIRECTION SHALL BE IN THE 45 DEGREE AREA TO FACE THE SAMPLE.

11.2.2.CHECKER SHALL SEE OVER 300±25 mm. WITH BARE EYES FAR FROM SAMPLE

Ambient Illumination:

Functional detection in 1000 nits backlight environment

Appearance detection in 800~1000 Lux external environment





11.3. INSPECTION PLAN :

CLASS	ITEM	JUDGEMENT	CLASS
PACKING & INDICATE	1. OUTSIDE AND INSIDE PACKAGE	"MODEL NO." , "LOT NO." AND "QUANTITY" SHOULD INDICATE ON THE PACKAGE.	Minor
	2. MODEL MIXED AND QUANTITY	OTHER MODEL MIXED.....REJECTED QUANTITY SHORT OR OVER.....REJECTED	Critical
	3. PRODUCT INDICATION	"MODEL NO." SHOULD INDICATE ON THE PRODUCT	Major
ASSEMBLY	4. DIMENSION, LCD GLASS SCRATCH AND SCRIBE DEFECT.	ACCORDING TO SPECIFICATION OR DRAWING.	Major
APPEARANCE	5. VIEWING AREA	POLARIZER EDGE OR LCD'S SEALING LINE IS VISABLE IN THE VIEWING AREAREJECTED	Minor
	6. BLEMISH · BLACK SPOT · WHITE SPOT IN THE LCD AND LCD GLASS CRACKS	ACCORDING TO STANDARD OF VISUAL INSPECTION(INSIDE VIEWING AREA)	Minor
	7. BLEMISH · BLACK SPOT WHITE SPOT AND SCRATCH ON THE POLARIZER	ACCORDING TO STANDARD OF VISUAL INSPECTION(INSIDE VIEWING AREA)	Minor
	8. BUBBLE IN POLARIZER	ACCORDING TO STANDARD OF VISUAL INSPECTION(INSIDE VIEWING AREA)	Minor
	9. LCD'S RAINBOW COLOR	STRONG DEVIATION COLOR (OR NEWTON RING) OF LCD.....REJECTED. OR ACCORDING TO LIMITED SAMPLE (IF NEEDED, AND INSIDE VIEWING AREA)	Minor
ELECTRICAL	10. ELECTRICAL AND OPTICAL CHARACTERISTICS (CONTRAST · VOP · CHROMATICITY ... ETC)	ACCORDING TO SPECIFICATION OR DRAWING . (INSIDE VIEWING AREA)	Critical
	11.MISSING LINE	MISSING DOT · LINE · CHARACTERREJECTED	Critical
	12.SHORT CIRCUIT · WRONG PATTERN DISPLAY	NO DISPLAY · WRONG PATTERN DISPLAY · CURRENT CONSUMPTION OUT OF SPECIFICATION..... REJECTED	Critical
	13. DOT DEFECT (FOR COLOR AND TFT)	ACCORDING TO STANDARD OF VISUAL INSPECTION	Minor



NO.	CLASS	ITEM	JUDGEMENT																				
11.4.1	MINOR	BLACK AND WHITE SPOT FOREIGN MATERIEL DUST IN THE CELL BLEMISH SCRATCH	<p>(A) ROUND TYPE: unit : mm.</p> <table border="1"> <thead> <tr> <th>DIAMETER (mm.)</th> <th>ACCEPTABLE Q'TY</th> </tr> </thead> <tbody> <tr> <td>$\Phi \leq 0.15$</td> <td>Distance>1mm</td> </tr> <tr> <td>$0.15 < \Phi \leq 0.4$</td> <td>3 (Distance>15mm)</td> </tr> <tr> <td>$0.4 < \Phi$</td> <td>0</td> </tr> </tbody> </table> <p>NOTE: $\Phi=(\text{LENGTH}+\text{WIDTH})/2$</p> <p>(B) LINEAR TYPE: unit : mm.</p> <table border="1"> <thead> <tr> <th>LENGTH</th> <th>WIDTH</th> <th>ACCEPTABLE Q'TY</th> </tr> </thead> <tbody> <tr> <td>-----</td> <td>$W \leq 0.03$</td> <td>Distance>1mm</td> </tr> <tr> <td>$L \leq 4.0$</td> <td>$0.03 < W \leq 0.05$</td> <td>3 (Distance>15mm)</td> </tr> <tr> <td>-----</td> <td>$0.05 < W$</td> <td>FOLLOW ROUND TYPE</td> </tr> </tbody> </table>	DIAMETER (mm.)	ACCEPTABLE Q'TY	$\Phi \leq 0.15$	Distance>1mm	$0.15 < \Phi \leq 0.4$	3 (Distance>15mm)	$0.4 < \Phi$	0	LENGTH	WIDTH	ACCEPTABLE Q'TY	-----	$W \leq 0.03$	Distance>1mm	$L \leq 4.0$	$0.03 < W \leq 0.05$	3 (Distance>15mm)	-----	$0.05 < W$	FOLLOW ROUND TYPE
DIAMETER (mm.)	ACCEPTABLE Q'TY																						
$\Phi \leq 0.15$	Distance>1mm																						
$0.15 < \Phi \leq 0.4$	3 (Distance>15mm)																						
$0.4 < \Phi$	0																						
LENGTH	WIDTH	ACCEPTABLE Q'TY																					
-----	$W \leq 0.03$	Distance>1mm																					
$L \leq 4.0$	$0.03 < W \leq 0.05$	3 (Distance>15mm)																					
-----	$0.05 < W$	FOLLOW ROUND TYPE																					
11.4.2	MINOR	BUBBLE IN POLARIZER DENT ON POLARIZER	<p style="text-align: right;">unit : mm.</p> <table border="1"> <thead> <tr> <th>DIAMETER</th> <th>ACCEPTABLE Q'TY</th> </tr> </thead> <tbody> <tr> <td>$\Phi \leq 0.2$</td> <td>Distance>1mm</td> </tr> <tr> <td>$0.2 < \Phi \leq 0.5$</td> <td>3 (Distance>15mm)</td> </tr> <tr> <td>$0.5 < \Phi$</td> <td>0</td> </tr> </tbody> </table>	DIAMETER	ACCEPTABLE Q'TY	$\Phi \leq 0.2$	Distance>1mm	$0.2 < \Phi \leq 0.5$	3 (Distance>15mm)	$0.5 < \Phi$	0												
DIAMETER	ACCEPTABLE Q'TY																						
$\Phi \leq 0.2$	Distance>1mm																						
$0.2 < \Phi \leq 0.5$	3 (Distance>15mm)																						
$0.5 < \Phi$	0																						
11.4.3	MINOR	Dot Defect	<table border="1"> <thead> <tr> <th>Items</th> <th>ACC. Q'TY</th> </tr> </thead> <tbody> <tr> <td>Bright dot</td> <td>$N \leq 2$ (Distance>15mm)</td> </tr> <tr> <td>Dark dot</td> <td>$N \leq 3$ (Distance>15mm)</td> </tr> </tbody> </table> <p>Pixel Define :</p> <p>Note 1: The definition of dot: The size of a defective dot over 1/2 of whole dot is regarded as one defective dot. Definition:<1/2dot and visible by 5% ND filter $N \leq 5$</p> <p>Note 2: Bright dot: Dots appear bright and unchanged in size in which LCD panel is displaying under black pattern.</p> <p>Note 3: Dark dot: Dots appear dark and unchanged in size in which LCD panel is displaying under pure red, green, blue pattern.</p>	Items	ACC. Q'TY	Bright dot	$N \leq 2$ (Distance>15mm)	Dark dot	$N \leq 3$ (Distance>15mm)														
Items	ACC. Q'TY																						
Bright dot	$N \leq 2$ (Distance>15mm)																						
Dark dot	$N \leq 3$ (Distance>15mm)																						
11.4.4	MINOR	Mura	Not visible through 5% ND filter in 50% gray or judge by limit sample if necessary																				

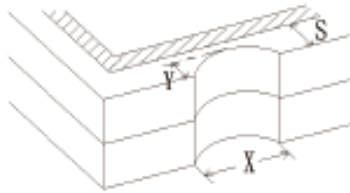
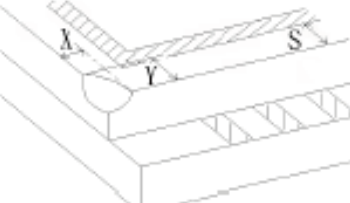

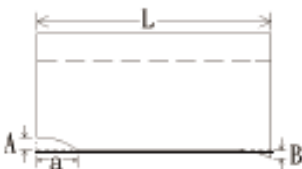
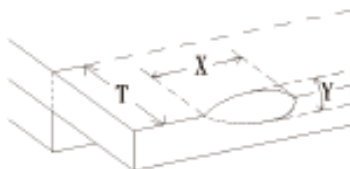
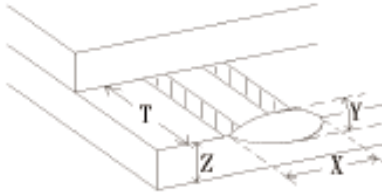
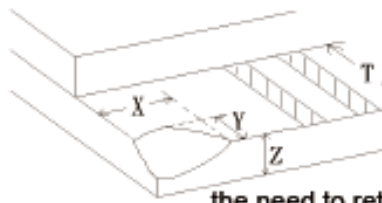
NO.	CLASS	ITEM	JUDGEMENT
11.4.5	MINOR	LCD GLASS CHIPPING	 <p>$X \geq 3\text{mm}$ $Y > S$</p> <p>Reject</p>
11.4.6	MINOR	LCD GLASS CHIPPING	 <p>$X \text{ or } Y > S$</p> <p>Reject</p>
11.4.7	MAJOR	LCD GLASS GLASS CRACK	 <p>Continuous burst NG</p> <p>Reject</p>
11.4.8	MAJOR	LCD GLASS SCRIBE DEFECT	 <p>ACCORDING TO DIMENSION</p>
11.4.9	MINOR	LCD GLASS CHIPPING (ON THE TERMINAL AREA)	 <p>$Y < 1/2Z$ $Y \geq 0.5\text{mm}$ $X \geq 3\text{mm}$</p> <p>Reject</p>
11.4.10	MINOR	LCD GLASS CHIPPING (ON THE TERMINAL SURFACE)	 <p>$Y < 1/2Z$ $Y \geq 0.5\text{mm}$ $X \geq 3\text{mm}$</p> <p>Reject</p>
11.4.11	MINOR	LCD GLASS CHIPPING	 <p>$X \geq 3\text{mm}$ $Y \geq T$</p> <p>Reject</p> <p>If touch the electrode lines, the need to retain the two-thirds electrode lines</p>



12. Handling Precautions

12.1 Mounting method

The LCD panel of KINGTECH TFT module consists of two thin glass plates with polarizers which easily be damaged. And since the module is so constructed as to be fixed by utilizing fitting holes in the printed circuit board.

Extreme care should be needed when handling the LCD modules.

12.2 Caution of LCD handling and cleaning

When cleaning the display surface, Use soft cloth with solvent

[Recommended below] and wipe lightly

- Isopropyl alcohol
- Ethyl alcohol

Do not wipe the display surface with dry or hard materials that will damage the polarizer surface.

Do not use the following solvent:

- Water
- Aromatics

Do not wipe ITO pad area with the dry or hard materials that will damage the ITO patterns

Do not use the following solvent on the pad or prevent it from being contaminated:

- Soldering flux
- Chlorine (Cl) , Sulfur (S)

If goods were sent without being silicon coated on the pad, ITO patterns could be damaged due to the corrosion as time goes on.

If ITO corrosion happens by miss-handling or using some materials such as Chlorine (Cl), Sulfur (S) from customer, Responsibility is on customer.

12.3 Caution against static charge

The LCD module uses C-MOS LSI drivers, so we recommend that you:

Connect any unused input terminal to Power or Ground, do not input any signals before power is turned on, and ground your body, work/assembly areas, and assembly equipment to protect against static electricity.

12.4 packing

- Module employs LCD elements and must be treated as such.
- Avoid intense shock and falls from a height.
- To prevent modules from degradation, do not operate or store them exposed direct to sunshine or high temperature/humidity

12.5 Caution for operation

- It is an indispensable condition to drive LCD's within the specified voltage limit since the higher voltage than the limit causes the shorter LCD life.
- An electrochemical reaction due to direct current causes LCD's undesirable deterioration, so that the use of direct current drive should be avoided.
- Response time will be extremely delayed at lower temperature than the operating temperature range and on the other hand at higher temperature LCD's show dark color in them. However those phenomena do not mean malfunction or out of order with LCD's, which will come back in the specified operation temperature.
- If the display area is pushed hard during operation, some font will be abnormally displayed but it resumes normal condition after turning off once.
- Slight dew depositing on terminals is a cause for electro-chemical reaction resulting in terminal open circuit.

Usage under the maximum operating temperature, 50%Rh or less is required.



12.6 storing

In the case of storing for a long period of time for instance, for years for the purpose or replacement use, the following ways are recommended.

- Storage in a polyethylene bag with the opening sealed so as not to enter fresh air outside in it. And with no desiccant.
- Placing in a dark place where neither exposure to direct sunlight nor light's keeping the storage temperature range.
- Storing with no touch on polarizer surface by the anything else.
[It is recommended to store them as they have been contained in the inner container at the time of delivery from us

12.7 Safety

- It is recommendable to crash damaged or unnecessary LCD's into pieces and wash off liquid crystal by either of solvents such as acetone and ethanol, which should be burned up later.
- When any liquid leaked out of a damaged glass cell comes in contact with your hands, please wash it off well with soap and water

13. Precaution for Use

13.1

A limit sample should be provided by the both parties on an occasion when the both parties agreed its necessity. Judgment by a limit sample shall take effect after the limit sample has been established and confirmed by the both parties.

13.2

On the following occasions, the handing of problem should be decided through discussion and agreement between responsible of the both parties.

- When a question is arisen in this specification
- When a new problem is arisen which is not specified in this specifications
- When an inspection specifications change or operating condition change in customer is reported to KINGTECH TFT , and some problem is arisen in this specification due to the change
- When a new problem is arisen at the customer's operating set for sample evaluation in the customer site.

14. Packing Method

TBD