



PRODUCT SPECIFICATION

MODEL: PV09500A0120A

< ◆ > PRELIMINARY SPECIFICATION

< ◇ > APPROVAL SPECIFICATION

CUSTOMER
APPROVED BY
DATE:

DESIGNED	CHECKED	APPROVED



REVISION RECORD

<u>REV NO</u>	<u>REV DATE</u>	<u>PAGE</u>	<u>CONTENTS</u>	<u>ISSUER</u>
1.0	2021-09-15	17	First Release	LiBingbing



TABLE OF CONTENT

■ GENERAL INFORMATION

主要特征描述

■ EXTERNAL DIMENSIONS

外形尺寸

■ ABSOLUTE MAXIMUM RATINGS

极限参数

■ ELECTRICAL CHARACTERISTICS

模块电气特性

■ ELECTRO-OPTICAL CHARACTERISTICS

光电参数

■ INTERFACE DESCRIPTION

接口定义描述

■ REFERENCE APPLICATION CIRCUIT

参考应用电路

■ RELIABILITY TEST CONDITIONS

可靠性试验条件

■ INSPECTION CRITERION

检查标准

■ PRECAUTIONS FOR USING LCM MODULES

使用注意事项

■ PACKING SPECIFICATION

包装规格书

■ PRIOR CONSULT MATTER

提前商议事项



1.0 GENERAL INFORMATION

Item	Contents	Unit
Display Mode	AMOLED	/
LTPS Glass Outline (WxH)	12.80 ×27.35	mm
Active area	10.8×21.6	mm
Number of Dots	120(RGB)×240	/
Diagonal Inch	0.95	inch
Pixel pitch (WxH)	90×90	um
Module Thickness	1.00	mm



2.0 EXTERNAL DIMENSIONS

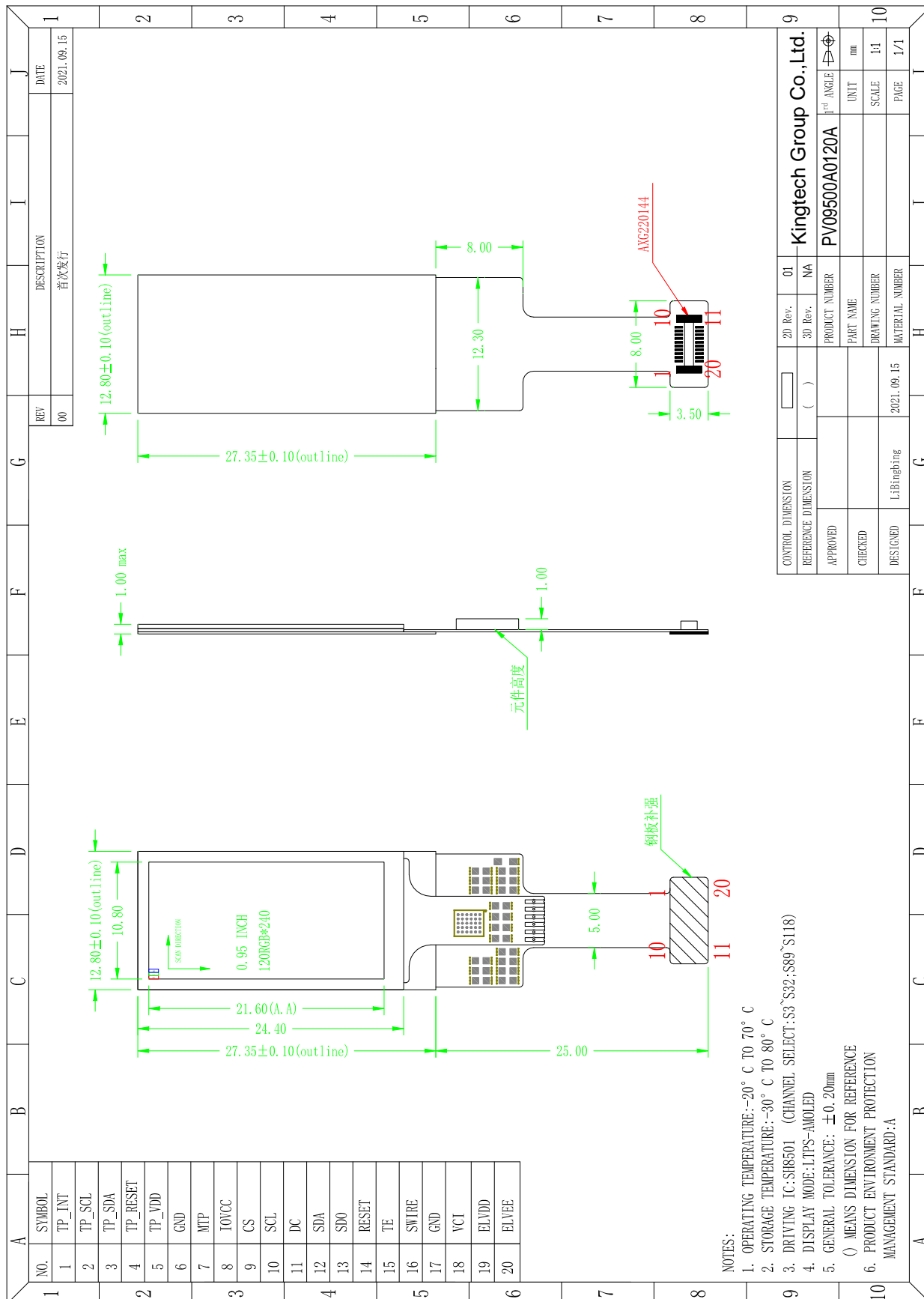



3.0 ABSOLUTE MAXIMUM RATINGS

Parameter	Symbol	Min	Max	Unit
Supply voltage (Display)	VCI	-0.3	5.5	V
	IOVCC	-0.3	5.5	V
	ELVDD	4.5	4.7	V
	ELVEE	-4.0	-0.6	V
Operating temperature	TOP	-20	70	°C
Storage temperature	TST	-30	80	°C
Humidity	RH	-	90	%RH

Note: Absolute maximum ratings means the product can withstand short-term, NOT more than 120 hours. If the product is a long time to withstand these conditions, the life time would be shorter.

4.0 ELECTRICAL CHARACTERISTICS

Parameter		Symbol	Condition	Min	Typ	Max	Unit
Supply voltage (Display)		VCI		2.7	2.8	2.9	V
		IOVCC		1.7	1.8	1.9	V
		ELVDD	-	4.55	4.6	4.65	V
		ELVEE	-	-2.45	-2.4	-2.35	V
Input voltage	'L' level	VIL	IOVCC=1.65	GND	-	0.2*IOVCC	V
	'H' level	VIH	V~3.3V	0.8*IOVCC	-	IOVCC	V
Output voltage	'L' level	VOL	I(OH)=-1mA	GND	-	0.2*IOVCC	V
	'H' level	VOH	I(OL)=+1mA	0.8*IOVCC	-	IOVCC	V
Current (Display)	Sleep out mode	IVCC	Full white display 450nits,60Hz	-	2.5	5	mA
		IIOVCC		-	1	2	mA
		IELVDD/ ELVEE		-	7	14	mA
	Sleep in mode	IVCC		-	12	24	uA
		IIOVCC		-	8	16	uA
	Deep Standby Mode	IVCC		-	1	3	uA
IIOVCC			-	0.1	1	uA	
Frame Frequency		fFRM		-	60	-	Hz



5.0 OPTICAL CHARACTERISTICS

Item	Symbol	Condition	Min	Type	Max	Unit	Note
Surface Luminance	Lv	$\theta=0^\circ$ $\varnothing=0^\circ$ $T_a=25^\circ\text{C}$	400	450	-	cd/m ²	Note1
Luminance uniformity	WHITE		80	-	-	%	Note2
Contrast Ratio	Cr		80000	-	-	-	Note3
Viewing Angle		Up/Down/Right/Left Cr \geq 200	80	-	-	deg	Note4
Color Coordinate of CIE1931	Red x	$\theta=0^\circ$ $\varnothing=0^\circ$ $T_a=25^\circ\text{C}$	0.630	0.660	0.690	-	Note 5
	Red y		0.310	0.340	0.370	-	
	Green x		0.170	0.220	0.270	-	
	Green y		0.680	0.730	0.780	-	
	Blue x		0.115	0.140	0.165	-	
	Blue y		0.025	0.050	0.075	-	
	White x		0.280	0.300	0.320	-	
	White y		0.290	0.310	0.330	-	
NTSC ratio	-	-	85	100	-	%	CIE1931
Gamma	-	$\theta=0^\circ$ $\varnothing=0^\circ$ $T_a=25^\circ\text{C}$ V(Gray)=44,68,100, 132,164,196,228,25 2,255	2.0	2.2	2.4	-	
Lifetime	T95	25°C	240	-	-	h	

Note1. Surface Luminance

- Measurement equipment: CS2000 or similar equipment.
- Measuring surroundings: Dark room.
- Measuring temperature: $T_a=25^\circ\text{C}$.
- The data are measured after OLEDs are lighted on for more than 5 minutes and all pixels are fully white.
- The Surface Luminance is the average value of 5 measured spots (Fig-1): $L_v = \text{Average Luminance with all white pixels (P1, P2, P3, P4, P5)}$

Note2. Luminance Uniformity

- Measurement equipment: CS2000 or similar equipment.
- Measuring surroundings: Dark room.
- Measuring temperature: $T_a=25^\circ\text{C}$.
- The data are measured after OLEDs are lighted on for more than 5 minutes and all pixels are fully white.



- The Luminance Uniformity is calculated by using following formula:

$$d \text{ WHITE} = L_p (\text{Min.}) / L_p (\text{Max.}) \times 100 (\%)$$

$L_p (\text{Min.})$ = Minimum Luminance with all white pixels (P1, P2, P3, P4, P5) $L_p (\text{Max.})$ =

Maximum Luminance with all white pixels (P1, P2, P3, P4, P5)

Note3. Contrast Ratio

- Measurement equipment: CS2000 or similar equipment.
- Measuring surroundings: Dark room.
- Measuring temperature: $T_a = 25^\circ\text{C}$.
- The data are measured after OLEDs are lighted on for more than 5 minutes.
- The Contrast Ratio is calculated by using following formula: $\text{Contrast Ratio}(\text{Cr}) = L_w / L_b$
 L_w = Average Luminance with all white pixels (P1, P2, P3, P4, P5) L_b = Average Luminance with all black pixels (P1, P2, P3, P4, P5)

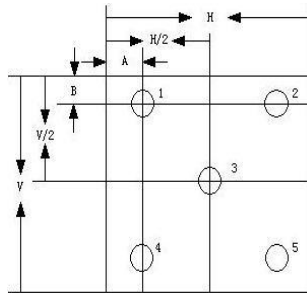

Note4. Viewing Angle

- Measurement equipment: DMS803 or similar equipment.
- Measuring surroundings: Dark room.
- Measuring temperature: $T_a = 25^\circ\text{C}$.

The Viewing Angle is the angle at which the contrast ratio is greater than 10. The angles are determined for the horizontal or x axis and the vertical or y axis with respect to the z axis which is normal to the display surface

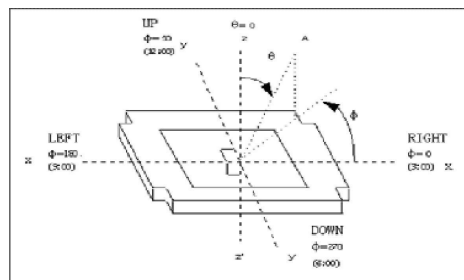

Note5. Color Coordinate of CIE1931

- Measurement equipment: CS2000 or similar equipment.
- Measuring surroundings: Dark room.
- Measuring temperature: $T_a = 25^\circ\text{C}$.
- The x, y value of Color Coordinate is determined by measuring at center position of the display panel.



6.0 INTERFACE DESCRIPTION

Inter face	Symbol	I/O or Connected to	Description	When not in use
1	TP_INT	O	Touch I2C ATTN interrupt.	/
2	TP_SCL	I	Touch I2C clock	/
3	TP_SDA	I/O	Touch I2C data	/
4	TP_RESET	I/O	Touch reset	/
5	TP_VDD	power	Power supply for Analog circuit.	/
6	GND	power	Ground	/
7	MTP	power	MTP programming power	/
8	IOVCC	power	Power supply for interface system	/
9	CS	I	Chip select input pin ("Low" enable) in SPI I/F.	Connect to IOVCC
10	SCL	I	A synchronous clock signal in SPI I/F.	Connect to GND
11	DC	I	Display data / command selection in 4-wire SPI I/F.	Connect to GND
12	SDA	I	LCD SPI data input	Open
13	SDO	O	LCD SPI data output	Open
14	RESET	I	This signal will reset the device and must be applied to properly initialize the chip.	Open
15	TE	O	Tearing effect output pin to synchronize MCU to frame writing, activated by S/W command.	Open
16	SWIRE	O	Swire protocol setting pin of Power IC.	Open
17	GND	power	Ground	/
18	VCI	power	Power supply for Analog circuit.	/
19	ELVDD	power	Power supply for pixel circuit.	/
20	ELVEE	power	Power supply for pixel circuit.	/



7.0 REFERENCE APPLICATION CIRCUIT

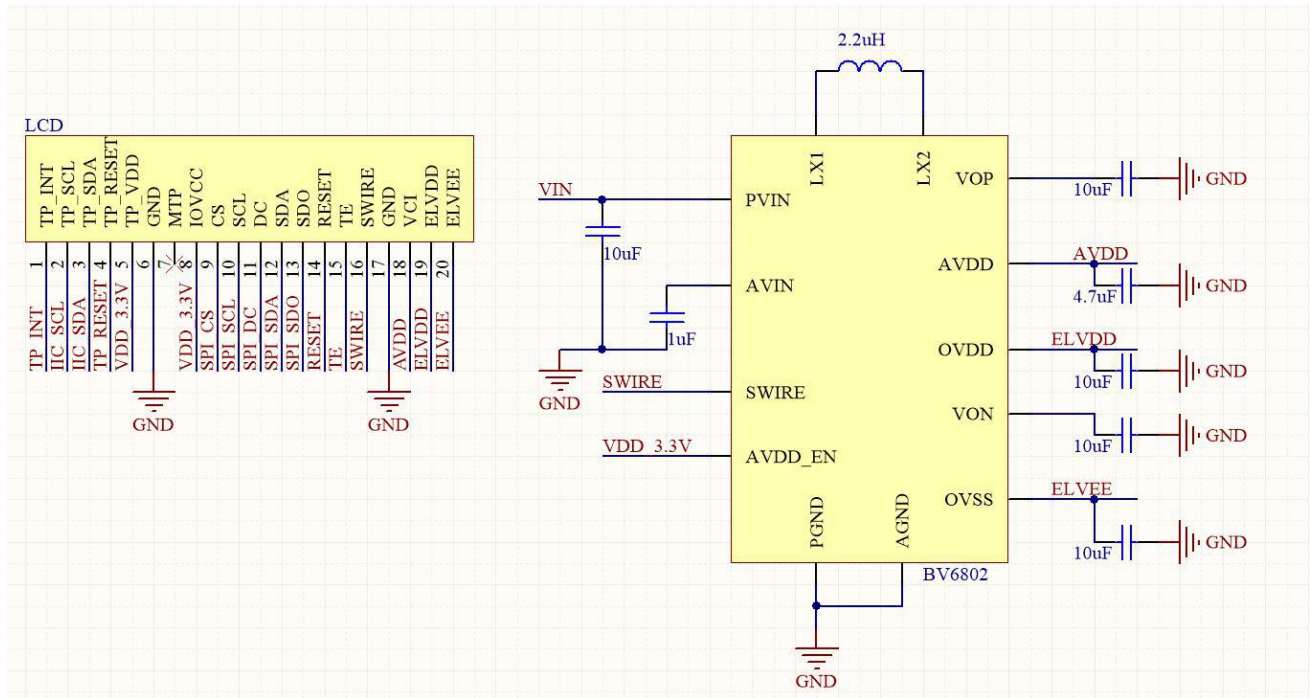



8.0 RELIABILITY TEST CONDITIONS

No.	Test Item	Test Condition	Qty	Inspection after test
1	High Temperature Storage	80°C±2°C/240 hours	5	Inspection after 2 hours storage at room temperature, the sample shall be free from defects: 1. Remarkable deterioration of No clearly visible defects or display quality. However, any polarizer's deteriorations by the high temperature/ High humidity Storage test and the High temperature/ High humidity Operation test are permitted. 2. No function-related abnormalities. 3. Optical criteria : .White $\Delta u'v' \leq 0.02$ 4. No visible defects .(optical / mechanical) . 5. No function-related abnormalities
2	Low Temperature Storage	-30°C±2°C/240 hours	5	
3	High Temperature Operating	70°C±2°C/120 hours	5	
4	Low Temperature Operating	-20°C±2°C/120 hours	5	
5	Temperature Cycle storage	-20°C±2°C~25~60°C±2°C×10cycles (30min.) (5min.) (30min.)	5	
6	High Temperature Humidity Storage	50°C±5°C×90%RH/120 hours	5	
7	ESD test	Voltage:±8KV R: 330Ω C: 150pF Air discharge, 10time	5	
8	Vibration Test	Frequency: 10Hz~55Hz~10Hz Amplitude: 1.5mm, X, Y, Z direction for total 3hours (Packing condition)	5	
9	Dropping test	Drop to the ground from 1m height, one time, every side of carton. (Packing condition)	5	

Remark:

1. The test samples should be applied to only one test item.
2. For Damp Proof Test, Pure water(Resistance > 10MΩ) should be used.
3. In case of malfunction defect caused by ESD damage, if it would be recovered to normal state after resetting, it would be judged as a good part.
4. Failure Judgment Criterion: Basic Specification, Electrical Characteristic, Mechanical Characteristic, Optical Characteristic.



9.0 RELIABILITY TEST CONDITIONS

9.1 抽样计划

按照抽样方案 GB/T2828.1-2003/ISO 2859-1: 1999 和 ANSI/ASQC Z1.4-1993 Level II 划分

品可以接受或拒绝的等级如下:

重缺陷: AQL 0.65

轻缺陷: AQL 1.5

9.2 检查条件

检查样品时, 外观检查的观察距离距检查者眼睛 30cm, 在 20~40W 日光灯的光照环境下 (外观检查亮度 1000±200 LUX; 功能检查亮度 100-300 LUX;), 保持检查样品应在垂直方向 45 度以内. (正常温度和湿度分别为 20~25°C, 60±15%RH)

9.3 检查区域定义:

屏幕显示区域定义:

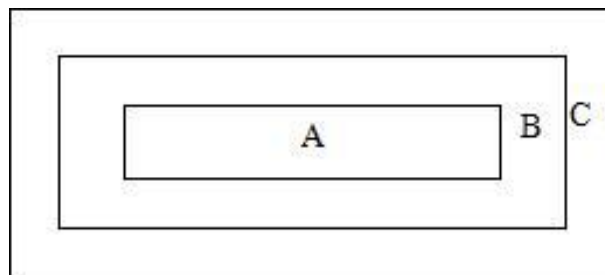

区域 A: 符号或数字显示区域

区域 B: 视区 (除 A 区) (A 区+B 区=最小视区, 相对于模块确认的 VA 区范围) 区域 C: 视区外围 (模块确认图的 VA 区外, 客户机装机后看不到此区域)

如上图: LCD 的检查区域定义

注意: 在区域 C 中看得见的缺陷, 但不影响产品质量以及客户组装, 允许出货。

9.4 贴合模组区域定义

Structure of 2D 2.5 D 3D 类型

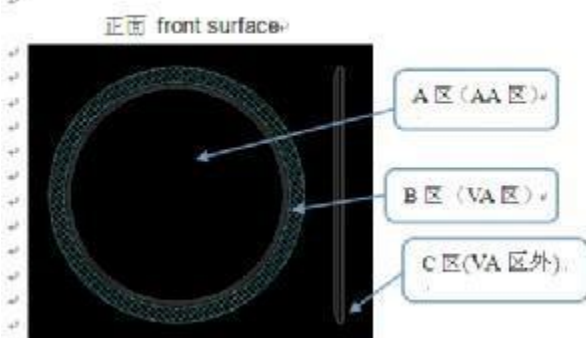

Structure of Boss 凸台类型

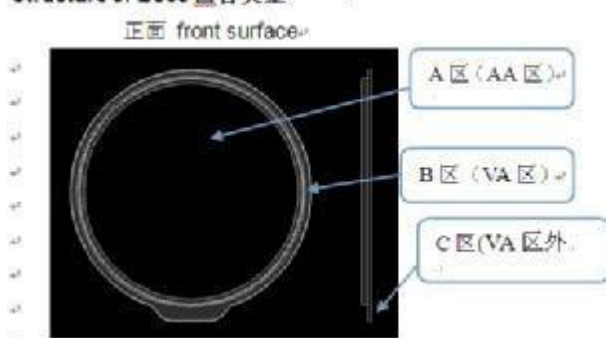

9.5 点线缺陷定义

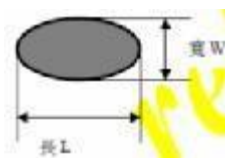



9.5.1 点状缺陷:

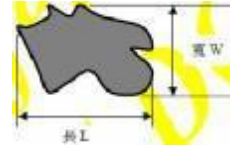

直径 $\Phi=1/2(L+W)$

直径 $\Phi=1/2(L+W)$

9.5.2 亮点:

一个像素由 3 个 DOT 点 (R,G,B) 构成, 任一 DOT 点面积的 1/2 称之为 1/2DOT;

在黑色界面下, 有红或绿或蓝任意一个像素被点亮, 统称为 DOT 亮点, 面积超过 1/2DOT 点即为不良 (小于 1/2 的 DOT 点不计入亮点数)

9.5.3 暗点:

在白色画面下, 有红或绿或蓝任意一个像素未点亮, 统称为 DOT 暗点, 面积超过 1/2DOT 点即为不良 (小于 1/2 的 DOT 点不计入暗点数)

9.5.4 异物亮点:

在黑色画面的由偏光片贴附或盒内异物导致发光的点; 碎亮点: 在黑色画面的由偏光片贴附或盒内异物导致发光的点; 直径 < 0.1mm

9.5.5 线状缺陷:

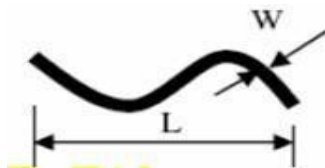

9.5.6 针孔 (透光) / 锯齿

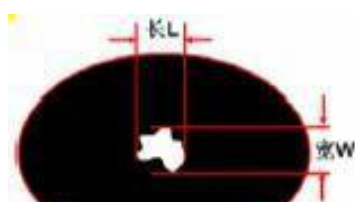

直径(Diameter)= $1/2(L+W)$





10.0 检查标准

参考 IIS

11.0 PRECAUTIONS FOR USING LCM MODULES

Handing Precautions

- 1 The display panel is made of glass and polarizer. As glass is fragile. It tends to become or chipped during handling especially on the edges. Please avoid dropping or jarring. Do not subject it to a mechanical shock by dropping it or impact.
- 2 Do not apply excessive force to the display surface or the adjoining areas since this may cause the color tone to vary. Do not touch the display with bare hands. This will stain the display area and degraded insulation between terminals (some cosmetics are determined to the polarizer).
- 3 The polarizer covering the display surface is soft and easily scratched. Handle this polarizer carefully. Do not touch, push or rub the exposed polarizers with anything harder than an HB pencil lead (glass, tweezers, etc.). Do not put or attach anything on the display area to avoid leaving marks on it. Condensation on the surface and contact with terminals due to cold will damage, stain or dirty the polarizer. After products are tested at low temperature they must be warmed up in a container before coming in to contact with room temperature air.
- 4 If the display surface becomes contaminated, breathe on the surface and gently wipe it with a soft dry cloth. If it is heavily contaminated, moisten cloth with one of the following solvents
 - Isopropyl alcohol
 - Ethyl alcoholDo not scrub hard to avoid damaging the display surface.
- 5 Solvents other than those above-mentioned may damage the polarizer. Especially, do not use the following.
 - Water
 - Ketone
 - Aromatic solventsWipe off saliva or water drops immediately, contact with water over a long period of time may cause deformation or color fading. Avoid contact with oil and fats.
- 6 Exercise care to minimize corrosion of the electrode. Corrosion of the electrodes is accelerated by water droplets, moisture condensation or a current flow in a high-humidity environment.



- 7 Do not attempt to disassemble or process the AM
- 8 NC terminal should be open. Do not connect anything.
- 9 If the logic circuit power is off, do not apply the input signals.
- 10 Electro-Static Discharge Control, Since this module uses a CMOS LSI, the same careful attention should be paid to electrostatic discharge as for an ordinary CMOS IC. To prevent destruction of the elements by static electricity, be careful to maintain an optimum work environment.
 - Before removing AMOLED from its packing case or incorporating it into a set, be sure the module and your body have the same electric potential. Be sure to ground the body when handling the AMOLED modules.
 - Tools required for assembling, such as soldering irons, must be properly grounded. Make certain the AC power source for the soldering iron does not leak. When using an electric screwdriver to attach AMOLED modules, the screwdriver should be of ground potentiality to minimize as much as possible any transmission of electromagnetic waves produced sparks coming from the commutator of the motor.
 - To reduce the amount of static electricity generated, do not conduct assembling and other work under dry conditions. To reduce the generation of static electricity be careful that the air in the work is not too dry. A relative humidity of 50%-60% is recommended. As far as possible make the electric potential of your work clothes and that of the work bench the ground potential.
 - The AMOLED module is coated with a film to protect the display surface. Exercise care when peeling off this protective film since static electricity may be generated.
 - The AMOLED module is coated with a film to protect the display surface. Exercise care when peeling off this protective film since static electricity may be generated.
- 11 Since AMOLED has been assembled and adjusted with a high degree of precision, avoid applying excessive shocks to the module or making any alterations or modifications to it.
 - Do not alter, modify or change the shape of the tab on the metal frame.
 - Do not make extra holes on the printed circuit board, modify its shape or change the positions of components to be attached.
 - Do not damage or modify the pattern writing on the printed circuit board.
 - Absolutely do not modify the zebra rubber strip (conductive rubber) or heat seal connector.
 - Except for soldering the interface, do not make any alterations or modifications with a soldering iron.
 - Do not drop, bend or twist the AMOLED.



Handling precaution for AMOLED

- 1 AMOLED is easy to be damaged. Please note below and be careful for handling.
- 2 Correct handling:
- 3 Incorrect handling:

Storage Precautions

- 1 When storing the AMOLED modules, the following precaution are necessary.
 - 1) Store them in a sealed polyethylene bag. If properly sealed, there is no need for the desiccant.
 - 2) Store them in a dark place. Do not expose to sunlight or fluorescent light, keep the temperature between 0°C and 35°C, and keep the relative humidity between 40%RH and 60%RH.
 - 3) The polarizer surface should not come in contact with any other objects (We advise you to store them in the anti-static electricity container in which they were shipped).

2 Transportation Precautions

- 1) During shipment, please handle with care. The packaging bag can not be broken, step on trap. Packaging Carton layer height can not be over two meters.
- 2) The transportation process should pay attention to the waterproof and moisture-proof measures. Product can not be watering. Ethylene sealed bags can not be unsealed.

3 Others

- 1) To minimize the performance degradation of the AMOLED modules resulting from destruction caused by static electricity etc., exercise care to avoid holding the following sections when handling the modules.
 - a) - Exposed area of the printed circuit board.
 - b) - Terminal electrode sections.



11 PACKING SPECIFICATION

Please consult our technical department for detail information.

详细信息请联系我们的技术部

12 PRIOR CONSULT MATTER

1 For KT standard products, we keep the right to change material, process ... for improving the product property without prior notice to our customer.

对于Kingtech的标准产品，我们保留在不通知客户的情况下,为提高产品性能而改变原材料及加工方法等的权利。

2 For OEM products, if any changes are needed which may affect the product property, we will consult with our customer in advance.

对于 OEM 产品，如果需要做任何会影响到产品性能的改变，我们会提前和客户商议。

3 If you have special requirement about reliability condition, please let us know before you start the test on our samples.

如对可靠性条件有特殊要求，请在模块测试前通知我们。