



PRODUCT SPECIFICATIONS

For Customer: _____

: APPROVAL FOR SPECIFICATION

Customer Model No. _____

: APPROVAL FOR SAMPLE

Module No.: PV03526D0130Z

Date : 2020-06-16

Table of Contents

No.	Item	Page
1	Cover Sheet(Table of Contents)	P1
2	Revision Record	P2
3	General Specifications	P3
4	Outline Drawing	P4
5	Absolute Maximum Ratings	P5
6	Electrical Specifications	P6-P11
7	Optical Characteristics	P12-P15
8	Reliability Test Items and Criteria	P16
9	Precautions for Use of LCD Modules	P17-P18

For Customer's Acceptance:

Approved By	Comment

PREPARED	CHECKED	VERIFIED BY QA DEPT	VERIFIED BY R&D DEPT
RCR			



3. General Specifications

PV03526D0130Z is a TFT-LCD module. It is composed of a TFT-LCD panel, driver IC, FPC, a back light unit. The 3.45'' display area contains 480 x (RGB) x 640 pixels and can display up to 16.7M colors. This product accords with ROHS environmental criterion.

Item	Contents	Unit	Note
LCD Type	TFT	-	
Display color	16.7M	Color	1
Viewing Direction	ALL	O'Clock	
Operating temperature	-20 ~ +70	°C	
Storage temperature	-30 ~ +80	°C	
Module size	76.74 X 63.74 X 3.20	mm	2
Active Area(W×H)	70.08 X 52.56	mm	
Number of Dots	640 X 480	dots	
Controller	NV3051	-	
Power Supply Voltage	2.8 & 1.8	V	
Backlight	6S-LEDs (white)	pcs	
Weight	---	g	
Interface	MIPI	-	

Note 1: Color tune is slightly changed by temperature and driving voltage.

Note 2: Without FPC and Solder.



5. Absolute Maximum Ratings(Ta=25 °C)

5.1 Electrical Absolute Maximum Ratings.(Vss=0V ,Ta=25 °C)

Item	Symbol	Min.	Max.	Unit	Note
Power Supply Voltage	IOVCC	-0.3	4.5	V	1,2
	VCI	-0.3	6.6		

Notes:

1. If the module is above these absolute maximum ratings. It may become permanently damaged. Using the module within the following electrical characteristic conditions are also exceeded, the module will malfunction and cause poor reliability.

2. $V_{CI} > V_{SS}$ must be maintained.

3. Please be sure users are grounded when handing LCD Module.

5.2 Environmental Absolute Maximum Ratings.

Item	Storage		Operating		Note
	MIN.	MAX.	MIN.	MAX.	
Ambient Temperature	-30 °C	80 °C	-20 °C	70 °C	1,2
Humidity	-	-	-	-	3

Notes:

1. The response time will become lower when operated at low temperature.

2. Background color changes slightly depending on ambient temperature.

The phenomenon is reversible.

3. $T_a \leq 40 \text{ °C}$:85%RH MAX.

$T_a > 40 \text{ °C}$:Absolute humidity must be lower than the humidity of 85%RH at 40 °C.



6. Electrical Specifications

6.1 Electrical characteristics (V_{SS}=0V, T_a=25°C)

Parameter	Symbol	Condition	Min	Typ	Max	Unit	
Power Supply Voltage	V _{CI}	T _a =25°C	2.5	2.8	3.6	V	
	IOVCC	T _a =25°C	1.65	1.8	3.6		
Input voltage	'H'	V _{IH}	T _a =25°C	0.7*IOVCC	-		IOVCC
	'L'	V _{IL}	T _a =25°C	0	-		0.3*IOVCC

6.2 LED backlight specification (V_{SS}=0V, T_a=25°C)

Item	Symbol	Condition	Min	Typ	Max	Unit	Note
Voltage for Backlight	V _f	I _f =20mA	16.2	18.0	19.8	V	
Uniformity	ΔBp	I _f =20mA	75	80	-	%	
Life Time	time	I _f =20mA	20K	-	-	hours	1

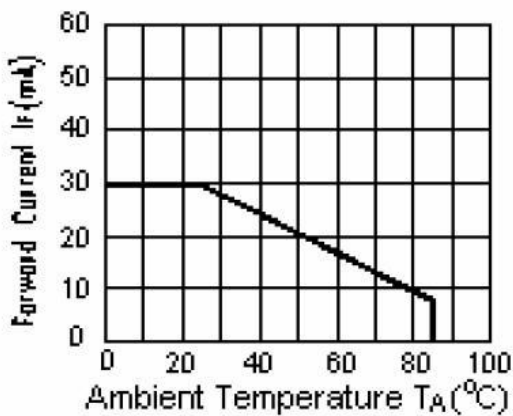

Note 1: Brightness to be decreased to 50% of the initial value at ambient temperature T_A=25°C



6.3 Interface signals

Pin No.	Symbol	I/O	Function
1-2	LED+	P	LED back light(Anode)
3	NC	-	No connection
4-5	LED-	P	LED back light(Cathode)
6-8	NC	-	No connection
9	GND	P	Ground.
10	D3P	I	MIPI DSI differential data (D3+)
11	D3N	I	MIPI DSI differential data (D3-)
12	GND	P	Ground.
13	D2P	I	MIPI DSI differential data (D2+)
14	D2N	I	MIPI DSI differential data (D2-)
15	GND	P	Ground.
16	CLKP	I	MIPI DSI differential clock(CLK+)
17	CLKN	I	MIPI DSI differential clock(CLK-)
18	GND	P	Ground.
19	D1P	I	MIPI DSI differential data (D1+)
20	D1N	I	MIPI DSI differential data (D1-)
21	GND	P	Ground.
22	D0P	I	MIPI DSI differential data (D0+)
23	D0N	I	MIPI DSI differential data (D0-)
24	GND	P	Ground.
25	TE	O	Tearing effect output pin is used to synchronize MCU frame writing,activated by S/W command.
26	RESET	I	Global Reset Signal. Active Low.
27	NC	-	No connection
28	VCI	P	Power supply for analog circuits.
29	IOVCC	P	External Power Supply for IO pads and other logic
30	NC	-	No connection



6.4 AC Characteristics

6.4.1 MIPI-DSI characteristics

6.4.1.1 High speed mode

Parameter	Symbol	Parameter	Specification			Unit
			MIN	TYP	MAX	
High Speed Mode						
DSI-CLK+/-	$2XU_{iinst}$	Double UI instantaneous	2.22	-	25	ns
DSI-CLK+/-	U_{iINSTA}, U_{iINSTB}	UI instantaneous Halfs	1.11	-	12.5	ns
DSI-Dn+/-	T_{ds}	Data to clock setup time	0.15	-	-	UI
DSI-Dn+/-	T_{dh}	Data to clock hold time	0.15	-	-	UI
DSI-CLK+/-	T_{drclk}	Differential rise time for clock	150	-	0.3UI	ps
DSI-Dn+/-	T_{drdata}	Differential rise time for data	150	-	0.3UI	ps
DSI-CLK+/-	T_{dfclk}	Differential fall time for clock	150	-	0.3UI	ps
DSI-Dn+/-	T_{dfdata}	Differential fall time for data	150	-	0.3UI	ps

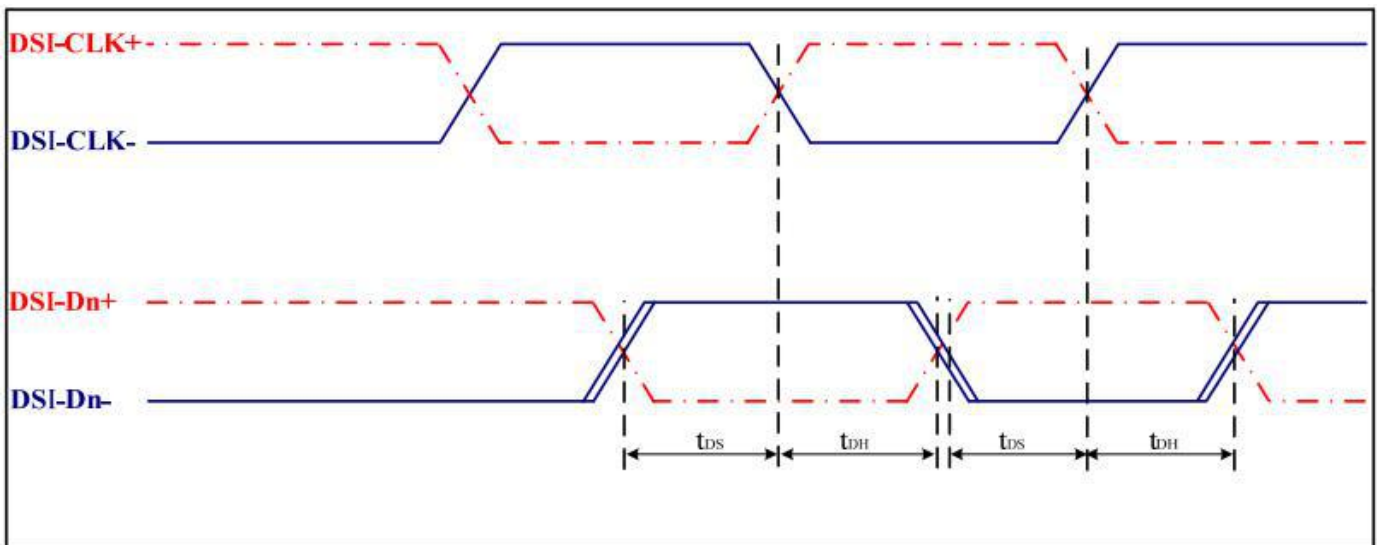
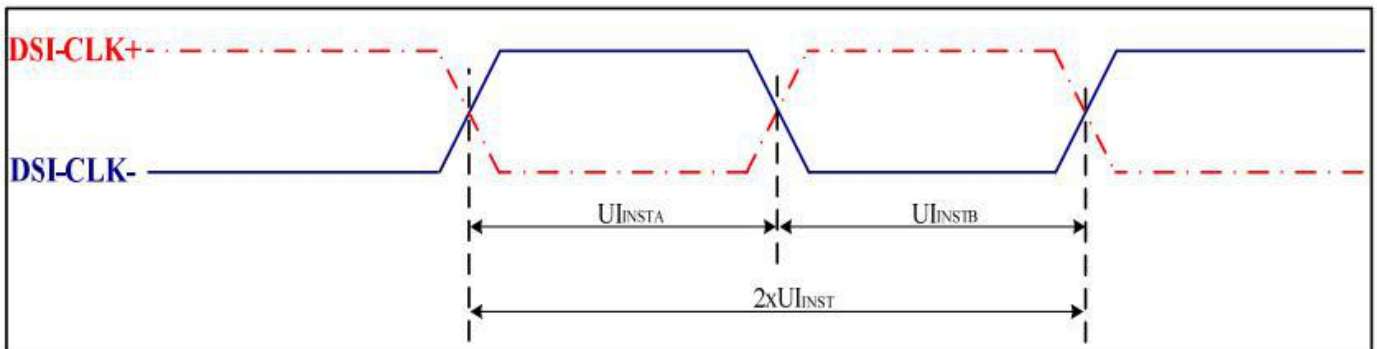

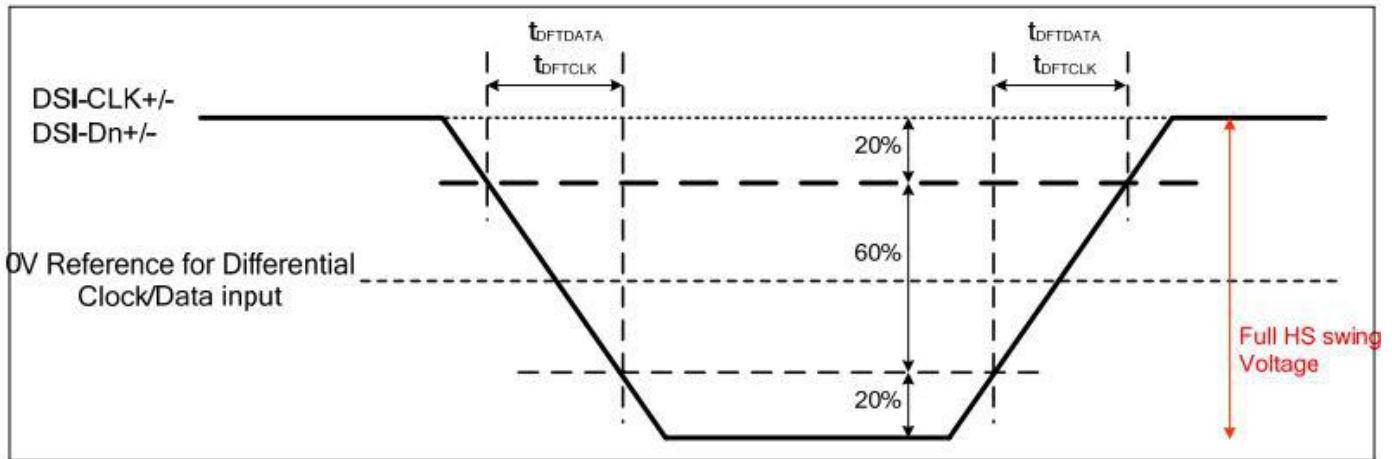

6.4.1.2 Low power mode

Parameter	Symbol	Parameter				Unit
			MIN	TYP	MAX	
Low Power Mode						
DSI-D0+/-	TLPXM	Length of LP-00, LP-01, LP-10 or LP-11 periods MPU Display Module	50	-	-	ns
DSI- D0+/-	TLPXD	Length of LP-00, LP-01, LP-10 or LP-11 periods Display Modulen MPU	58	-	-	ns
DSI- D0+/-	TTA-SURED	Time-out before the MPU start driving	TLPXD	-	2XTLPXD	ns
DSI- D0+/-	TTA-GETD	Time to drive LP-00 by display module	5XTLPXD	-	-	ns
DSI- D0+/-	TTA-GOD	Time to drive LP-00 after turnaround request – MPU	4XTLPXD	-	-	ns
DSI- D0+/-	Ratio TLPX	Ratio of TLPXM / TLPXD between MCU and display module	2/3	-	3/2	

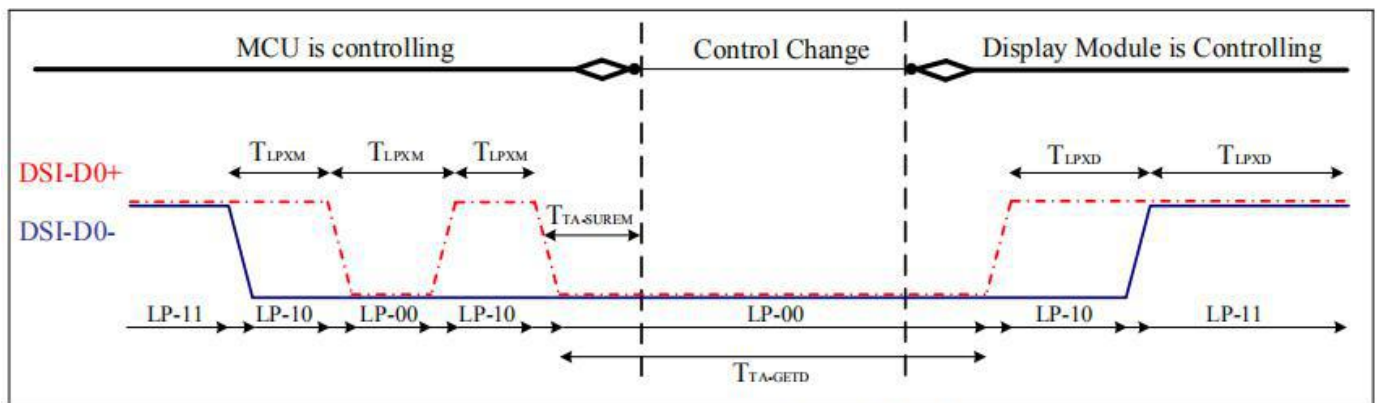

Figure: BTA from the MCU to the Display Module

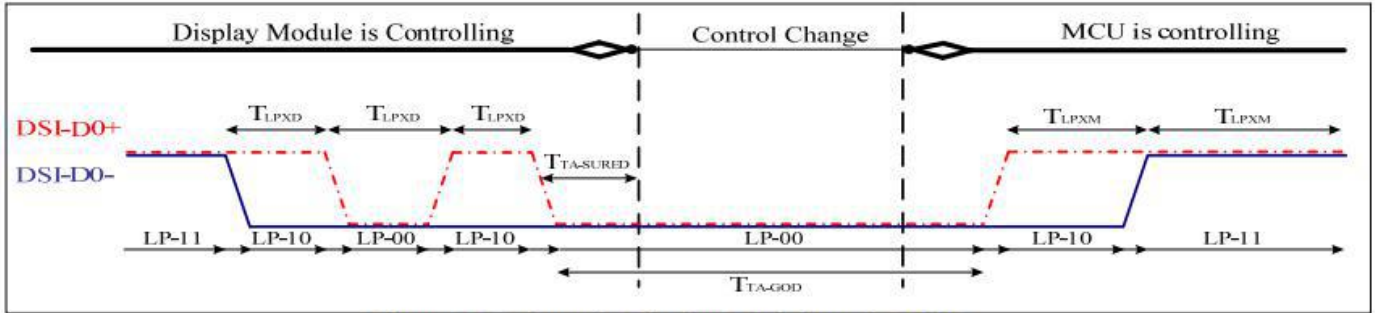
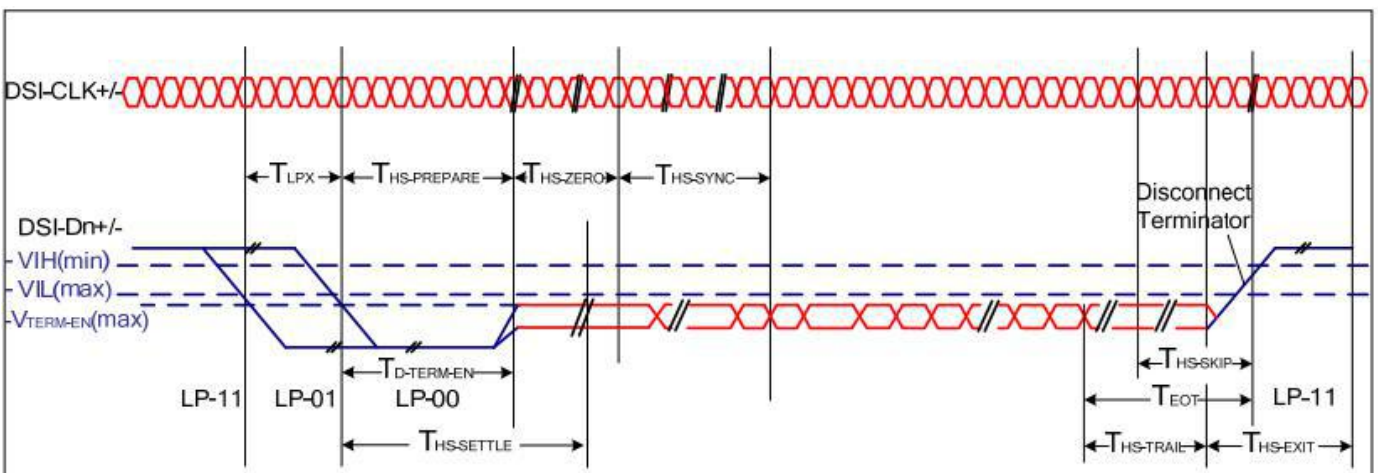

Figure: BTA from the Display Module to the MCU

6.4.1.3 Bursts

Parameter	Symbol	Parameter	Specification			Unit
			MIN	TYP	MAX	
High Speed Data Transmission Bursts						
DSI-Dn+/-	TLPX	Length of any low-power state period	50	-	-	ns
DSI- Dn+/-	THS- PREPARE	Time to drive LP-00 to prepare for HS transmission	40ns+4UI	-	85ns+6UI	ns
DSI- Dn+/-	THS- PREPARE+THS- ZERO	THS-PREPARE+time to drive HS-0 before the sync sequence	145ns+10UI	-	-	ns
DSI- Dn+/-	TD-TERM- EN	Time to enable Data Lane receiver line termination measured from when Dn crosses VIL(max)	Time for Dn to reach VTERM-EN	-	35ns+4UI	ns
DSI- Dn+/-	THS-SKIP	Time-out at RX to ignore transition period of EoT	40	-	55ns+4UI	ns
DSI- Dn+/-	THS-TRAIL	Time to drive flipped differential state after last payload data bit of a HS transmission burst	max (8UI, 60ns+4UI)	-	-	ns
DSI- Dn+/-	THS-EXIT	Time to drive LP-11 after HS burst	100	-	-	ns
DSI- Dn+/-	TeoT	Time from start of THS-TRAIL period to start of LP-11 state	-	-	105ns+12UI	ns





Parameter	Symbol	Parameter	Specification			Unit
			MIN	TYP	MAX	
Switching the clock Lane between clock Transmission and Low Power Mode						
DSI-CLK+/-	TCLK-POST	Time that the transmitter shall continue sending HS clock after the last associated Data Lane has transitioned to LP mode	60ns+52UI	-	-	ns
DSI-CLK+/-	TCLK-PRE	Time that the HS clock shall be driven prior to any associated Data Lane beginning the transition from LP to HS mode	8	-	-	UI
DSI-CLK+/-	TCLK-PREPARE	Time to drive LP-00 to prepare for HS clock transmission	38	-	95	ns
DSI-CLK+/-	TCLK-TERM- EN	Time to enable Clock Lane receiver line termination measured from when Dn crosses $V_{IL(max)}$	Time for Dn to reach $V_{TERM-EN}$	-	38	ns
DSI-CLK+/-	TCLK-PREPARE +TCLK-ZERO	TCLK-PREPARE + time for lead HS-0 drive period before starting Clock	300	-	-	ns
DSI-CLK+/-	TCLK-TRAIL	Time to drive HS differential state after last payload clock bit of a HS transmission burst	60	-	-	ns
DSI-CLK+/-	TeoT	Time from start of TCLK-TRAIL period to start of LP-11 state	-	-	105ns+12UI	ns

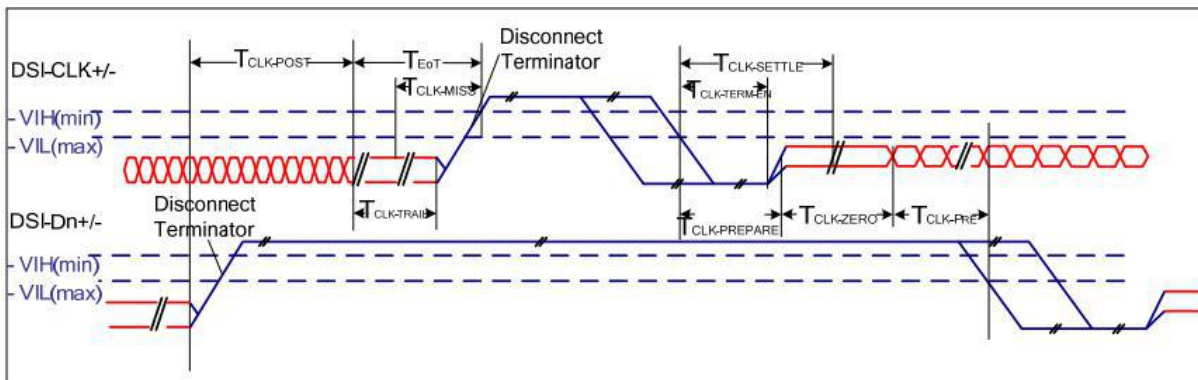

6.4.2 Reset timing characteristics

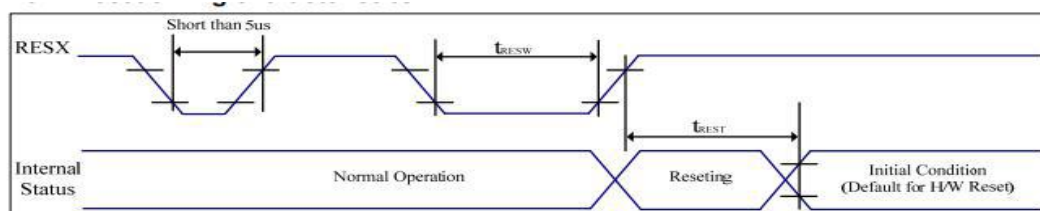

VSS=0V, IOVCC=1.65V to 3.6V, VCI=2.5V to 6.0V, Ta = -30°C to 70°C

Symbol	Parameter	Related Pins	MIN	TYP	MAX	Note	Unit
T_{resw}	*1) Reset low pulse width	RESX	10	-	-	-	us
T_{rest}	*2) Reset complete time	-	-	-	5	When reset applied during Sleep in mode	ms
		-	-	-	120	When reset applied during Sleep out mode	ms

Table: Reset input timing

Note 1: Due to an electrostatic discharge on RESX line, spike does not cause irregular system reset according to the table below.



7. Optical Characteristics

Item	Symbol	Condition	Min.	Typ.	Max.	Unit	Note	
Brightness	Bp	$\theta=0^\circ$ $\Phi=0^\circ$	-	500	-	Cd/m ²	1	
Uniformity	Δ Bp		75	80	-	%	1,2	
Viewing Angle	3:00	Cr \geq 10	-	80	-	Deg	3	
	6:00		-	80	-			
	9:00		-	80	-			
	12:00		-	80	-			
Contrast Ratio	Cr	$\theta=0^\circ$ $\Phi=0^\circ$	600	800	-	-	4	
Response Time	T _r +T _f		-	25	50	ms	5	
Color of CIE Coordinate	W	x	$\theta=0^\circ$ $\Phi=0^\circ$	Typ. -0.05	0.314	Typ. +0.05	-	1,6
		y			0.357		-	
	R	x			TBD		-	
		y			TBD		-	
	G	x			TBD		-	
		y			TBD		-	
	B	x			TBD		-	
		y			TBD		-	
NTSC	S		45	50	-	%		

Note: The parameter is slightly changed by temperature, driving voltage and materiel



Note 1: The data are measured after LEDs are turned on for 5 minutes. LCM displays full white. The brightness is the average value of 9 measured spots. Measurement equipment BM-7 (Φ5mm)

Measuring condition:

- *Measuring surroundings: Dark room.*
- *Measuring temperature: Ta=25 °C.*
- *Adjust operating voltage to get optimum contrast at the center of the display.*

Measured value at the center point of LCD panel after more than 5 minutes while backlight turning on.

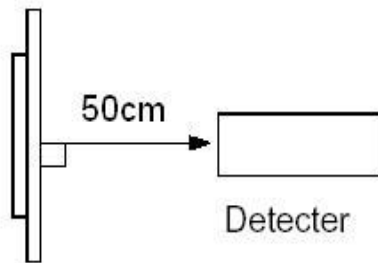

Note 2: The luminance uniformity is calculated by using following formula.

$$\Delta Bp = Bp (\text{Min.}) / Bp (\text{Max.}) \times 100 (\%)$$

Bp (Max.) = Maximum brightness in 9 measured spots

Bp (Min.) = Minimum brightness in 9 measured spots.

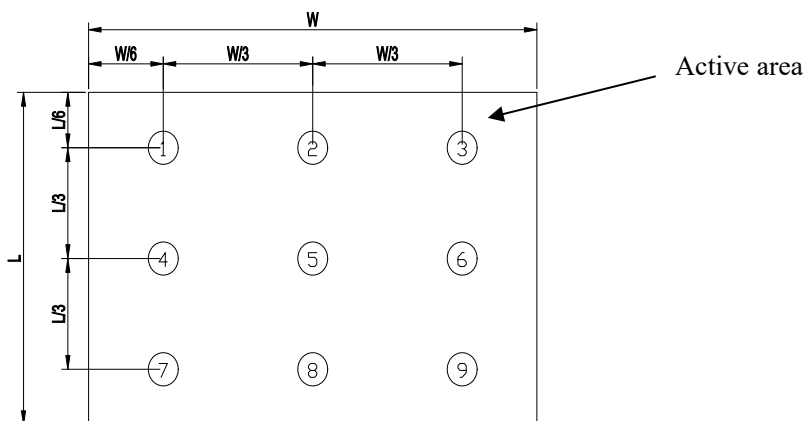



Note 3: The definition of viewing angle:
 Refer to the graph below marked by θ and Φ

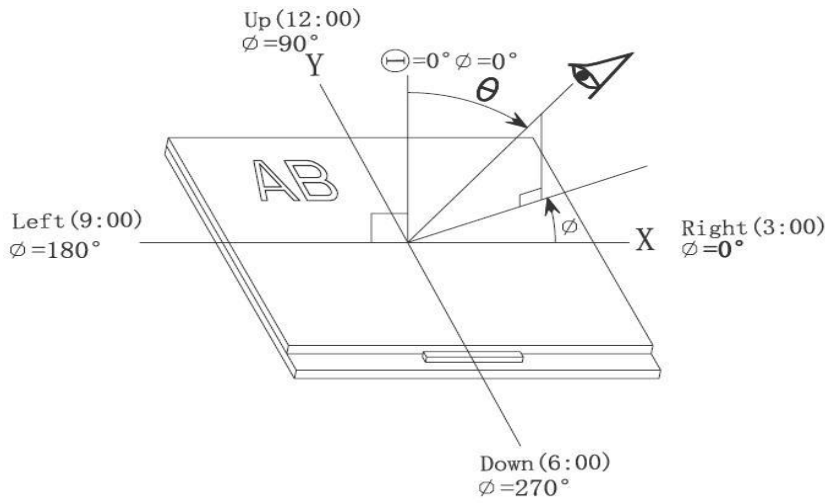

Note 4: Definition of contrast ratio.(Test LCD using DMS501)

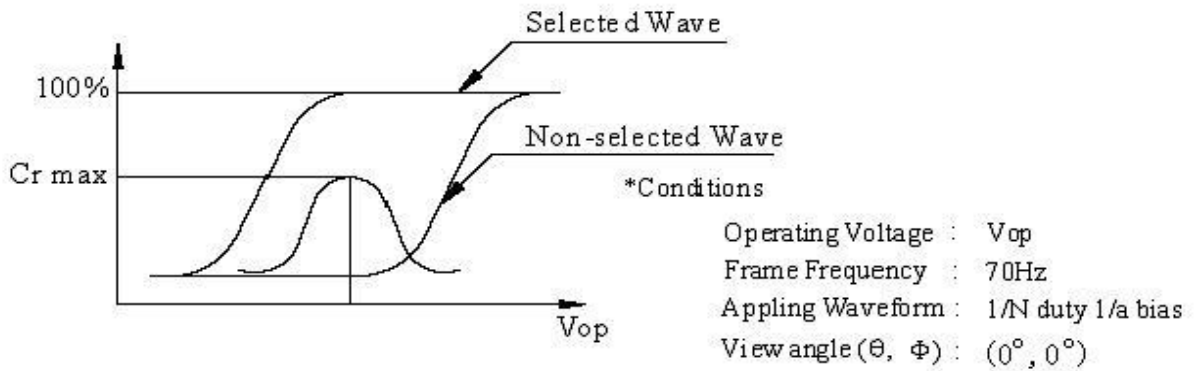

$$\text{Contrast ratio}(Cr) = \frac{\text{Brightness of selected dots}}{\text{Brightness of non-selected dots}}$$

Note 5: Definition of Response time. (Test LCD using DMS501):

The output signals of photo detector are measured when the input signals are changed from “black” to “white”(falling time) and from “white” to “black”(rising time), respectively. The response time is defined as the time interval between the 10% and 90% of amplitudes. Refer to figure as below.

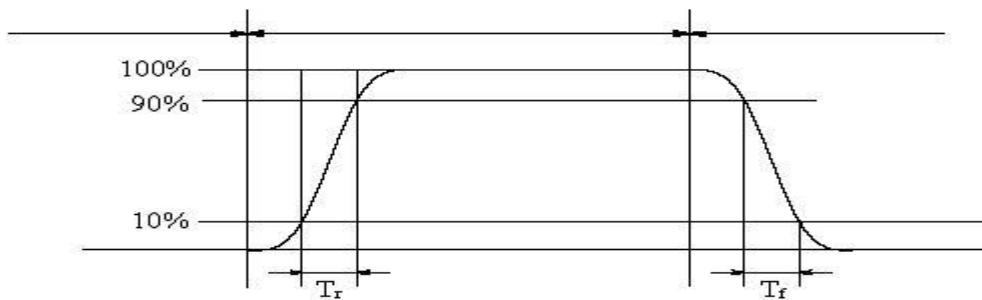

The definition of response time



Note 6: Definition of Color of CIE Coordinate and NTSC Ratio.

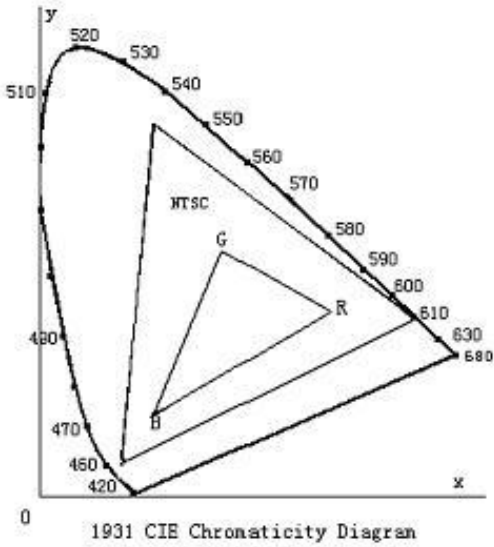

Color gamut:

$$S = \frac{\text{area of RGB triangle}}{\text{area of NTSC triangle}} \times 100\%$$

Note 7: Definition of cross talk.

$$\text{Cross talk ratio}(\%) = \frac{|\text{pattern A Brightness} - \text{pattern B Brightness}|}{\text{pattern A Brightness}} \times 100$$

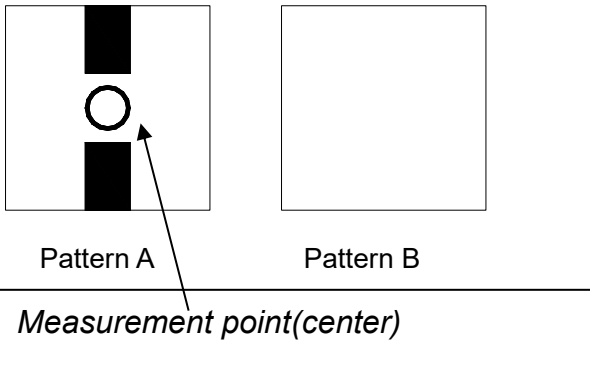

Electric volume value = 3F +/- 3Hex



8. Reliability Test Items and Criteria

Test Item	Test condition	Remark
High Temperature Storage	Ta = 80°C 96hrs	Note1,Note3,4
Low Temperature Storage	Ta = -30°C 96hrs	Note1,Note3,4
High Temperature Operation	Ta = 70°C 96hrs	Note2,Note3,4
Low Temperature Operation	Ta = -20°C 96hrs	Note1,Note3,4
Operation at High Temperature/Humidity	+60°C, 90%RH 96hrs	Note3,Note4
Thermal Shock	-30°C/30 min ~ +80°C/30 min for a total 10 cycles, Start with cold temperature and end with high temperature.	Note3,Note4
Vibration Test	Frequency range:10~55Hz Stroke:1.5mm Sweep:10Hz~55Hz~10Hz 2 hours for each direction of X. Y. Z. (6 hours for total)	
Mechanical Shock	100G 6ms,±X, ±Y, ±Z 3 times for each direction	
Package Vibration Test	Random Vibration : 0.015G*G/Hz from 5-200HZ, -6dB/Octave from 200-500HZ 2 hours for each direction of X. Y. Z. (6 hours for total)	
Package Drop Test	Height:60cm 1 corner, 3 edges, 6 surfaces	
Electro Static Discharge	±2KV, Human Body Mode, 100pF/1500Ω	

Note 1: Ta is the ambient temperature of samples.

Note 2: Ts is the temperature of panel's surface.

Note 3: In the standard condition, there shall be no practical problem that may affect the display function. After the reliability test, the product only guarantees operation, but don't guarantee all of the cosmetic specification.

Note 4: Before cosmetic and function test, the product must have enough recovery time,at least 2 hours at room temperature



9. Precautions for Use of LCD Modules

9.1 Handling Precautions

9.1.1 The display panel is made of glass. Do not subject it to a mechanical shock by dropping it from a high place, etc.

9.1.2 If the display panel is damaged and the liquid crystal substance inside it leaks out, be sure not to get any in your mouth, if the substance comes into contact with your skin or clothes, promptly wash it off using soap and water.

9.1.3 Do not apply excessive force to the display surface or the adjoining areas since this may cause the color tone to vary.

9.1.4 The polarizer covering the display surface of the LCD module is soft and easily scratched. Handle this polarizer carefully.

9.1.5 If the display surface is contaminated, breathe on the surface and gently wipe it with a soft dry cloth. If still not completely clear, moisten cloth with one of the following solvents:

— Isopropyl alcohol — Ethyl alcohol

Solvents other than those mentioned above may damage the polarizer. Especially, do not use the following:

— Water — Ketone — Aromatic solvents

9.1.6 Do not attempt to disassemble the LCD Module.

9.1.7 If the logic circuit power is off, do not apply the input signals.

9.1.8 To prevent destruction of the elements by static electricity, be careful to maintain an optimum work environment.

a. Be sure to ground the body when handling the LCD Modules.

b. Tools required for assembly, such as soldering irons, must be properly ground.

c. To reduce the amount of static electricity generated, do not conduct assembly and other work under dry conditions.

d. The LCD Module is coated with a film to protect the display surface. Be care when peeling off this protective film since static electricity may be generated.



9.2 Storage precautions

9.2.1 *When storing the LCD modules, avoid exposure to direct sunlight or to the light of fluorescent lamps.*

9.2.2 *The LCD modules should be stored under the storage temperature range. If the LCD modules will be stored for a long time, the recommend condition is:*

Temperature : 0 °C ~ 40 °C

Relatively humidity: ≤80%

9.2.3 *The LCD modules should be stored in the room without acid, alkali and harmful gas.*

9.3 *The LCD modules should be no falling and violent shocking during transportation, and also should avoid excessive press, water, damp and sunshine.*

END