



承认编码: CR

TFT LCD MODULE
2.4 inch 240RGB*320DOTS

MODULE NUMBER: DW0240A2BZ

REVISION: V00

Customer Approval:

--

- Approved For Specifications
- Approved For Specifications & Sample**

Prepared by	Checked by	Approved by



Index

Contents	Page
1. LCM Specification	4
2. Mechanical Specification.....	5
3. Pin Descriptions.....	6
4. Electrical Units.....	7
5. AC Characteristics.....	9
6.Optical Specifications.....	12
7. Reliability Test Items.....	16
8. Package(TBD).....	17
9. Handling Precautions.....	17
10. QC.....	18



1. LCM Specification

1.1 Description

DW0240A2BZ is a transmissive type color active matrix liquid crystal display(LCD) which uses amorphous thin film transistor(TFT) as switching devices. This product is composed of a TFT LCD panel, a drive IC, a FPC and a LED-backlight unit. The active display area is 2.4 inches diagonally measured and the native resolution is 240*RGB*320.Features of this product are listed in the following table.

1.2 Functions & Features

Table 1.1 Module Functions & Features

Parameter	Value	Unit
LCD Mode	TFT/Transmissive	-
Color Depth	262 K	-
Display Resolution	240RGB*320	pixels
Module Size	60.26(H)*42.72(W)*2.5(T)(Exclude FPC)	mm
Active Area (A.A)	48.96(H)*36.72(W)	mm
Pixel Arrangement	RGB-stripe	-
Viewing Direction	6 O' clock	
Display Mode	Normally white	
LCD Controller/Driver	ILI9341	-
IC Package Type	COG	-
Interface	8,9,16,18-bits MPU / 6,16,18-bits RGB / 3,4 Wire SPI.	-
Power Supply Voltage	2.5~3.3	V
Back-light	White LED*4	PCS



2. Mechanical Specification

1	LED-K	21	DB12
2	LED-A	22	DB11
3	GND	23	DB10
4	VCI	24	DB09
5	RESET	25	DB08
6	RS_SCL	26	DB07
7	/RD	27	DB06
8	/CS	28	DB05
9	SDA	29	DB04
10	WR_D/C	30	DB03
11	VSYNC	31	DB02
12	HSYNC	32	DB01
13	DOTCLK	33	DB00
14	DE	34	TE
15	GND	35	GND
16	DB17	36	IOVCC
17	DB16	37	NC(XR)
18	DB15	38	NC(YD)
19	DB14	39	NC(XL)
20	DB13	40	NC(YU)

VCI: 2.5 - 3.3V
IOVCC: 1.65 - 3.3V

BACKLIGHT CIRCUIT

REV.	1	DESCRIPTION	DATE	APPROVE:
		新制訂	20130617	CHECK:
				DRAWN:
				王加林

TITLE:		DW0240A2BZ	
DOC. NO.			
PART NO.			
REV.	1.0	SHEET	1 OF 1
SCALE		1:1	
UNITS		mm	

Display Type	TFT/Normally white/TRANSMISSIVE
Display Resolution	DOTS: 240*(RGB)*320
Viewing Angle	6 °clock
LCD Controller/Driver	ILI9341
Logic Voltage	2.8V
Operation Temperature	-20°C ~ 70°C
Storage Temperature	-30°C ~ 80°C
Backlight Spec.	White LED (49ies in Parallel) I=60±5mA V=3.2V



3. Pin Descriptions

Pin No.	Symbol	I/O	Functional	Remark
1	LEDK	P	LED Power supply -	
2	LEDA	P	LED Power supply +	
3	GND	P	System ground.	
4	VCI	P	Power supply, 2.5~3.3V	
5	RESET	I	Reset signal pin.	
6	RS_SCL	I	Register select signal (80-system) or serial interface clock in 3-wire/ 4-wire .	
7	/RD	I	80-system : /RD (read strobe signal)	
8	/CS	I	80-system: Chip select pin.	
9	SDA	I/O	Serial Data in/out signal.	
10	WR_D/C	I	80-system: Serves Write signal 4-line system: Command or Parameter select.	
11	VSYNC	I	Vertical synchronizing signal.	
12	HSYNC	I	Horizontal synchronizing signal.	
13	DOTCLK	I	Dot clock signal	
14	DE	I	Data ENABLE signal	
15	GND	P	System ground.	
16~33	DB17~DB0	I/O	Data bus	
34	TE	O	Tearing effect output. (If not used, please open this pin.)	
35	GND	P	System ground.	
36	IOVCC	P	Logic Power supply: 1.65~3.3V	
37	TP_R	I	TOUCH PANEL CONTROL PIN (N.C)	
38	TP_D	I		
39	TP_L	I		
40	TP_U	I		

- 说明:
1. 根据客户需要可在 FPC 上设置为 8, 9, 16, 18-bits 的 MPU 接口及 3 线或 4 线 SPI 接口, 也可设置为 6, 16, 18-bits 的 RGB 接口(此时在 FPC 上必须设置为 SPI)
 2. 默认接口模式为 16-bits 的 MPU 接口。

Instructions :

1. According to customer requirements, the FPC can be set up as MPU 8,9,16 and 18bit interface; 3 or 4 wire SPI interface; 6,16,18bit RGB interface (But for RGB, it must be set as SPI interface on FPC).

2. The default interface is MPU 16bits. If customer changes interface at their side after receiving samples from us, please remind us to change too when mass production.



4. Electrical Units

4.1 Absolute Maximum Ratings

The absolute maximum ratings are list on Table 4.1. When used out of the absolute maximum ratings, the LCM may be permanently damaged. Using the LCM within the following electrical characteristics limit is strongly recommended for normal operation. If these electrical characteristic conditions are exceeded during normal operation, the LCM will malfunction and cause poor reliability.

Table 4.1 Module Absolute Maximum Ratings

Item	Symbol	Unit	Value	Note
Power Supply Voltage (1)	Vdd	V	-0.3 to +4.0	
Power Supply Voltage (2)	VGH ~ VSS	V	-0.3 to +17.0	
Power Supply Voltage (3)	VSS ~ VGL	V	0 to -12.0	
Operating Temperature	Top	°C	-10 to +60	
Storage Temperature	Tst	°C	-20 to +70	
Operating Humidity	Hop	%(RH)	10~85	

(VSS=0V)

4.2 Electrical characteristics (Ta=25°C)

Table 4.2:DC Characteristic (Vcc = 3.0 ~ 3.6V)

Item		Symbol	Condition	Min.	Type.	Max.	Unit
Supply Voltage	Logic	Vdd	---	2.5	2.8	3.3	V
Input Voltage	H level	V _{IH}	---	0.7V _{dd}	---	V _{dd}	V
	L level	V _{IL}		0	---	0.3V _{dd}	
Current Consumption		I _{DD}	With internal voltage generation; VDD=3.3V; Tamb=25°C;	---	--	--	mA



4.3 Back-light Specification

Table 4.3 Back-light Characteristics

Item	Symbol	Conditions	Min.	Type.	Max.	Unit
Supply Voltage	VF	Only Backlight	--	3.2	3.3	V
Supply Current	IF		60			mA
Average Brightness	IV	Backlight Current IF=60mA	200	220	-	Cd/m ²
CIE Color Coordinate (Without LCD)	X	Backlight Current IF=60mA	--	0.27	--	-
	Y		--	0.27	--	
Uniformity	B	Backlight Current IF=60mA	--	80%	-	%
Color	White					

Note: 4 LEDs in parallel connection.



5. AC Characteristics

5.1 Parallel MPU interface operation

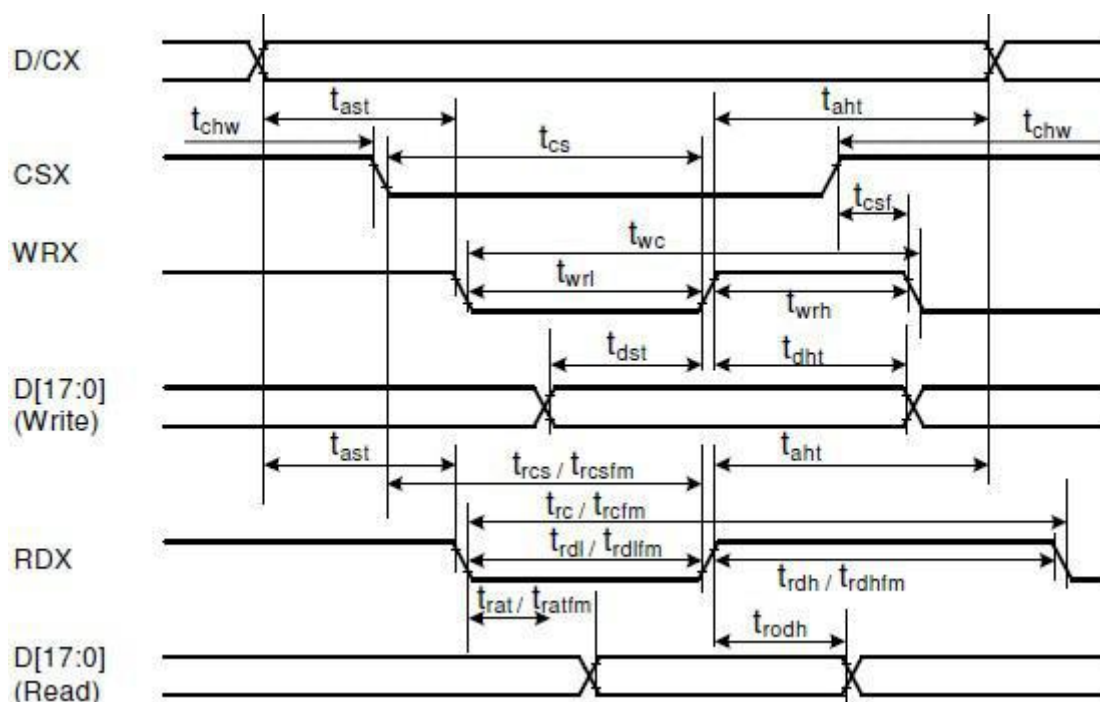

Signal	Symbol	Parameter	min	max	Unit
DCX	tast	Address setup time	0	-	ns
	taht	Address hold time (Write/Read)	0	-	ns
CSX	tchw	CSX "H" pulse width	0	-	ns
	tcs	Chip Select setup time (Write)	15	-	ns
	trcs	Chip Select setup time (Read ID)	45	-	ns
	trcsfm	Chip Select setup time (Read FM)	355	-	ns
	tcsf	Chip Select Wait time (Write/Read)	10	-	ns
WRX	twc	Write cycle	66	-	ns
	twrh	Write Control pulse H duration	15	-	ns
	twrl	Write Control pulse L duration	15	-	ns
RDX (FM)	trcfm	Read Cycle (FM)	450	-	ns
	trdhfm	Read Control H duration (FM)	90	-	ns
	trdlfm	Read Control L duration (FM)	355	-	ns
RDX (ID)	trc	Read cycle (ID)	160	-	ns
	trdh	Read Control pulse H duration	90	-	ns
	trdl	Read Control pulse L duration	45	-	ns
D[17:0], D[15:0], D[8:0], D[7:0]	tdst	Write data setup time	10	-	ns
	tdht	Write data hold time	10	-	ns
	trat	Read access time	-	40	ns
	tratfm	Read access time	-	340	ns
	trod	Read output disable time	20	80	ns



5.2 3-line SPI

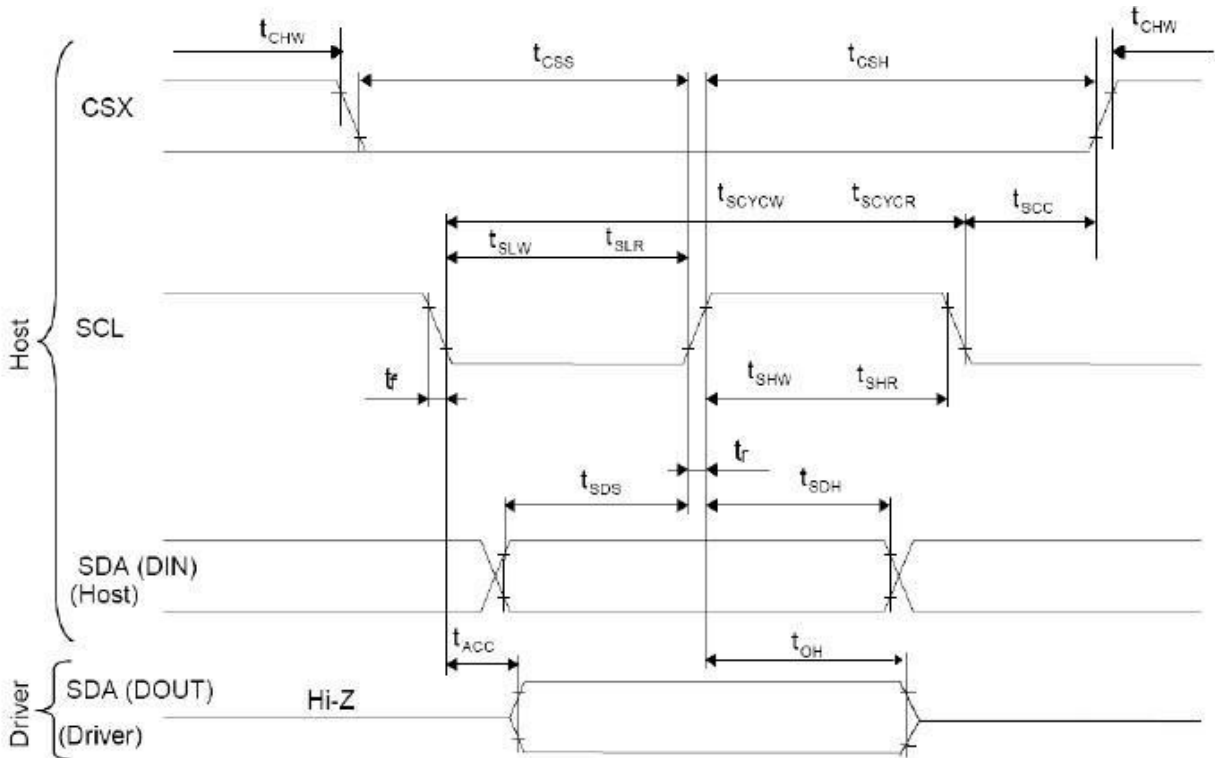

Signal	Symbol	Parameter	min	max	Unit
SCL	tscycw	Serial Clock Cycle (Write)	100	-	ns
	tshw	SCL "H" Pulse Width (Write)	40	-	ns
	tslw	SCL "L" Pulse Width (Write)	40	-	ns
	tscycr	Serial Clock Cycle (Read)	150	-	ns
	tshr	SCL "H" Pulse Width (Read)	60	-	ns
	tslr	SCL "L" Pulse Width (Read)	60	-	ns
SDA / SDI (Input)	tsds	Data setup time (Write)	30	-	ns
	tsdh	Data hold time (Write)	30	-	ns
SDA / SDO (Output)	tacc	Access time (Read)	10	-	ns
	toh	Output disable time (Read)	10	50	ns
CSX	tsc	SCL-CSX	20	-	ns
	tchw	CSX "H" Pulse Width	40	-	ns
	tcss	CSX-SCL Time	60	-	ns
	tcs		65	-	ns

Note: $T_a = 25\text{ }^\circ\text{C}$, $V_{DDI}=1.65\text{V to }3.3\text{V}$, $V_{CI}=2.5\text{V to }3.3\text{V}$, $AGND=V_{SS}=0\text{V}$



5.3 4-line SPI

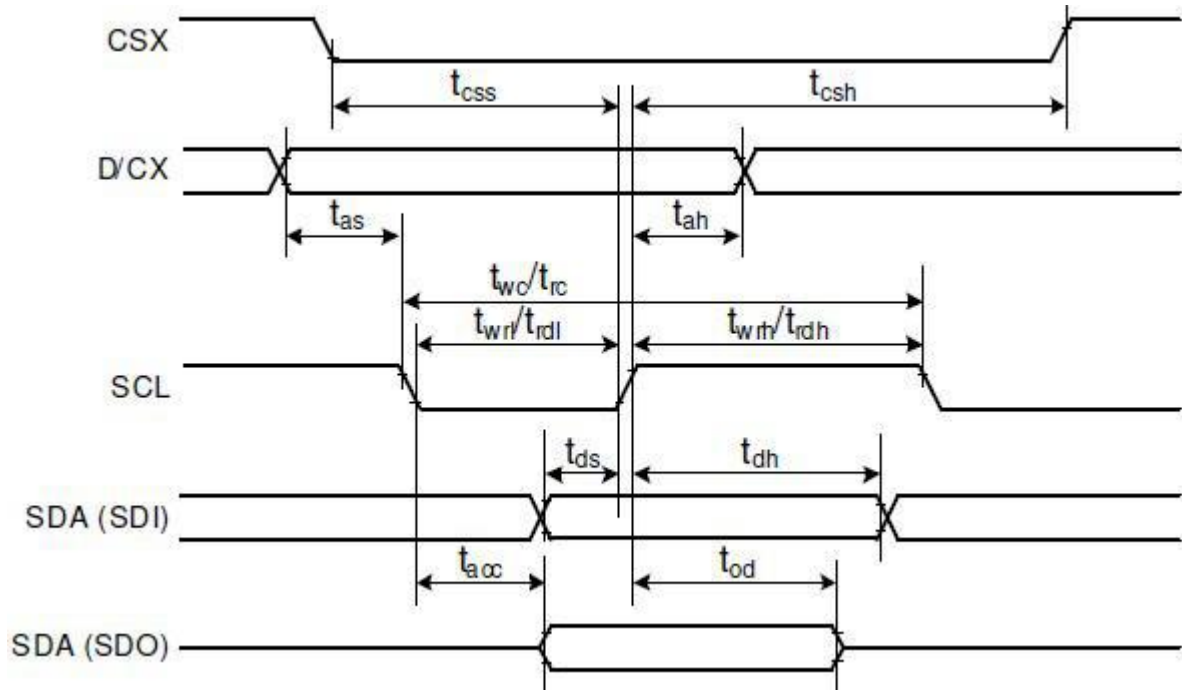

Signal	Symbol	Parameter	min	max	Unit
CSX	t_{css}	Chip select time (Write)	40	-	ns
	t_{csh}	Chip select hold time (Read)	40	-	ns
SCL	t_{wc}	Serial clock cycle (Write)	100	-	ns
	t_{wrh}	SCL "H" pulse width (Write)	40	-	ns
	t_{wrl}	SCL "L" pulse width (Write)	40	-	ns
	t_{rc}	Serial clock cycle (Read)	150	-	ns
	t_{rdh}	SCL "H" pulse width (Read)	60	-	ns
	t_{rdl}	SCL "L" pulse width (Read)	60	-	ns
D/CX	t_{as}	D/CX setup time	10	-	
	t_{ah}	D/CX hold time (Write / Read)	10	-	
SDA / SDI (Input)	t_{ds}	Data setup time (Write)	30	-	ns
	t_{dh}	Data hold time (Write)	30	-	ns
SDA / SDO (Output)	t_{acc}	Access time (Read)	10	-	ns
	t_{od}	Output disable time (Read)	10	50	ns

Note: $T_a = 25\text{ }^\circ\text{C}$, $V_{DDI}=1.65\text{V to }3.3\text{V}$, $V_{CI}=2.5\text{V to }3.3\text{V}$, $AGND=VSS=0\text{V}$



5.4 RGB interface operation

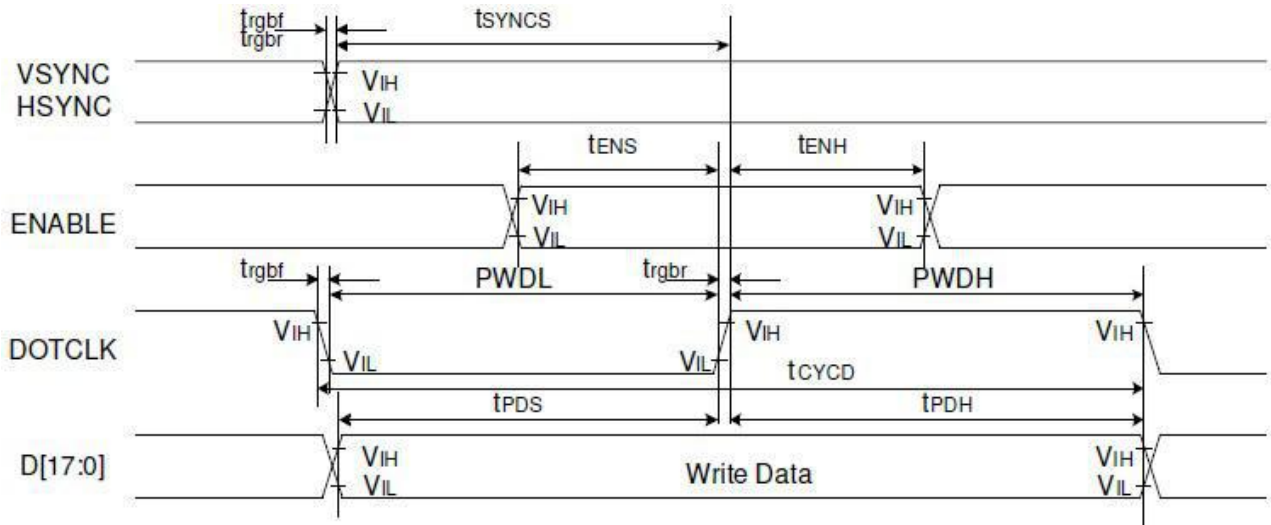

Signal	Symbol	Parameter	min	max	Unit	Description
VSYNC / HSYNC	t_{SYNCS}	VSYNC/HSYNC setup time	15	-	ns	18/16-bit bus RGB interface mode
	t_{SYNCH}	VSYNC/HSYNC hold time	15	-	ns	
DE	t_{ENS}	DE setup time	15	-	ns	
	t_{ENH}	DE hold time	15	-	ns	
D[17:0]	t_{POS}	Data setup time	15	-	ns	
	t_{PDH}	Data hold time	15	-	ns	
DOTCLK	$PWDH$	DOTCLK high-level period	15	-	ns	
	$PWDL$	DOTCLK low-level period	15	-	ns	
	t_{CYCD}	DOTCLK cycle time	100	-	ns	
	t_{rgrb}, t_{rgbf}	DOTCLK, HSYNC, VSYNC rise/fall time	-	15	ns	
VSYNC / HSYNC	t_{SYNCS}	VSYNC/HSYNC setup time	15	-	ns	6-bit bus RGB interface mode
	t_{SYNCH}	VSYNC/HSYNC hold time	15	-	ns	
DE	t_{ENS}	DE setup time	15	-	ns	
	t_{ENH}	DE hold time	15	-	ns	
D[17:0]	t_{POS}	Data setup time	15	-	ns	
	t_{PDH}	Data hold time	15	-	ns	
DOTCLK	$PWDH$	DOTCLK high-level pulse period	15	-	ns	
	$PWDL$	DOTCLK low-level pulse period	15	-	ns	
	t_{CYCD}	DOTCLK cycle time	100	-	ns	
	t_{rgrb}, t_{rgbf}	DOTCLK, HSYNC, VSYNC rise/fall time	-	15	ns	

Note: $T_a = -30$ to 70 °C, $V_{DDI} = 1.65V$ to $3.3V$, $V_{CI} = 2.5V$ to $3.3V$, $AGND = VSS = 0V$



6. Optical Specifications

Optical characteristics are determined after the unit has been 'ON' and stable for approximately 30 minutes in a dark environment at 25°C. The values specified are at an approximate distance 50cm from the TFT-LCD surface at a viewing angle of Φ and θ equal to 0° .

Measurement condition: Refer to next pages (C-light source, Halogen Lamp)

*1): with Polarizer *2): without Polarizer *3): Only Color Filter glass

Item	Symbol	Conditions	Specifications			Unit	
			Min.	Typ.	Max.		
Transmittance	T%	Viewing normal angle $\theta_x = \theta_y = 0^\circ$	4.5	5.0	-	%	
Contrast Ratio	CR		-	250	-		
Response Time (by Quick)	$T_{on} + T_{off}$		-	30	-	ms	
Viewing Angle	Hor.	θ_{x+}	Center CR>10	-	45	-	deg.
		θ_{x-}		-	45	-	
	Ver.	θ_{y+}		-	45	-	
		θ_{y-}		-	20	-	
CF only Color Chromaticity (CIE 1931)	Red	X_R	Viewing normal angle $\theta_x = \theta_y = 0^\circ$	0.592	0.612	0.632	
		Y_R		0.309	0.329	0.349	
	Green	X_G		0.279	0.299	0.319	
		Y_G		0.547	0.567	0.587	
	Blue	X_B		0.124	0.144	0.164	
		Y_B		0.090	0.110	0.130	
	White	X_W		0.288	0.308	0.328	
		Y_W		0.305	0.325	0.345	



Notes : 1. Contrast Ratio(CR) is defined mathematically as :

$$\text{Contrast Ratio} = \frac{\text{Surface Luminance with all white pixels}}{\text{Surface Luminance with all black pixels}}$$

2. Surface luminance is the center point across the TFT-LCD surface 500mm from the surface with all pixels displaying white. For more information see FIG 1.
3. Response time is the time required for the display to transition from white to black(Rise Time, T_r) and from black to white(Falling Time, T_f). For additional information see FIG 3.
4. Viewing angle is the angle at which the contrast ratio is greater than 10. The angles are determined for the horizontal or x axis and the vertical or y axis with respect to the z axis which is normal to the TFT-LCD surface. For more information see FIG 4.
5. Optimum contrast is obtained by adjusting the TFT-LCD Threshold voltage(V_{th} & V_{sat})

FIG. 1 Optical Characteristic Measurement Equipment and Method

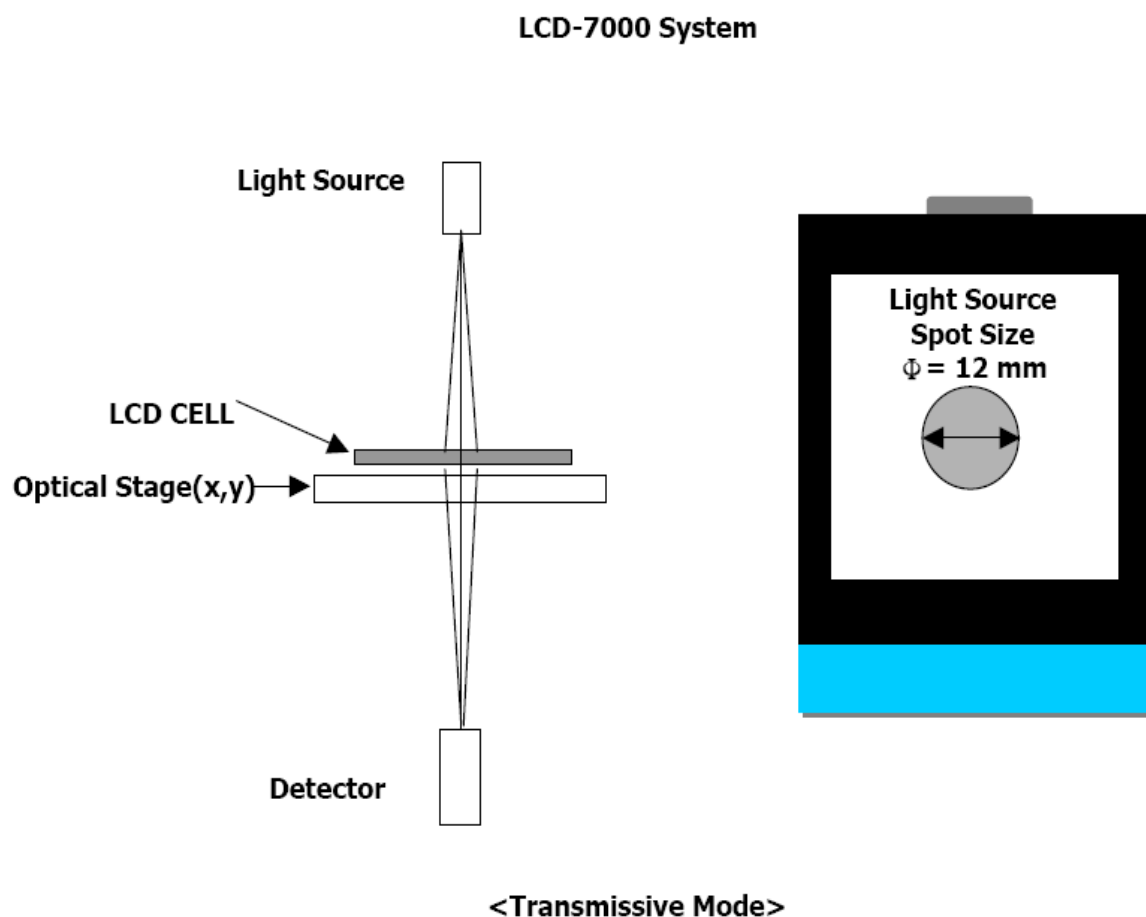



FIG. 2 The definition of V_{th} and V_{sat}

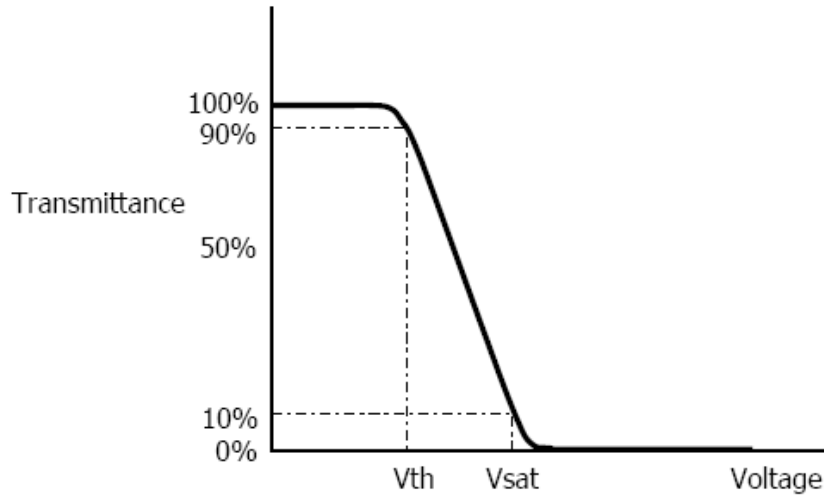
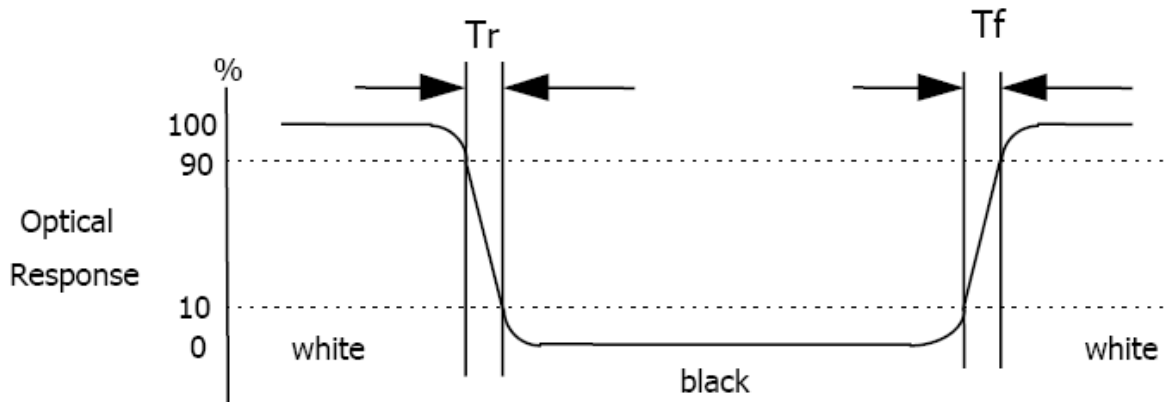

FIG. 3 The definition of Response Time

The response time is defined as the following figure and shall be measured by switching the input signal for "black" and "white".



* Voltage conditions for Response time

Vgate : 19V DC

Vdata : 0V~3.3V DC

Vcom : 0V (Ground)



FIG. 4 The definition of viewing angle

<dimension of viewing angle range>

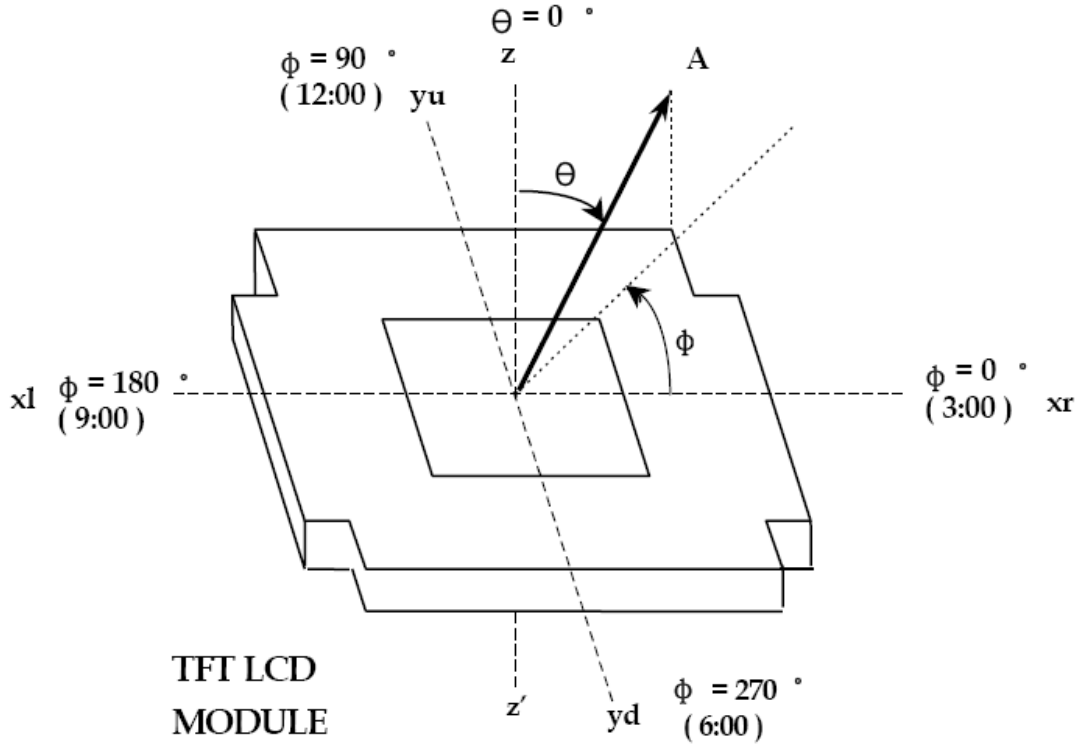



7. Reliability Test Items

No.	Test Item	Test Condition	Check Time
1	High temp storage	T=70°C	72Hrs
2	Low temp storage	T=-20°C	72Hrs
3	High temp operation	T=60°C	72Hrs
4	Low temp operation	T=-10°C	72Hrs
5	High temp & high humidity	T=50°C H=85%	72Hrs

Reliability Test Criteria:

Display function should be no change under normal operating condition.



8. Package(TBD)

9. Handling Precautions

9.1 Safety

The liquid crystal in the LCD is poisonous. Keep away from your mouth and eyes. If the liquid crystal contacts with your skin, mouse or clothes, use soap to wash it off immediately.

9.2 Handling

- i. The LCD panel is made of very thin glass. Mechanical impact or extrusion to the surface should be prevented.
- ii. The polarizer attached on the display is very easy to be damaged, handle it with special attention.
- iii. To avoid contamination on the display surface, do not touch the display surface with bare hands.
- iv. The transparent electrodes may be disconnected if you use the LCD panel under dew-condensing environment.
- v. The characteristics of the semiconductor devices may be affected when they are exposed to light, possibly resulting in malfunctioning of the ICs. To prevent such malfunctioning of the ICs, make sure the application and the mounting of the panel are designed so that the IC is not exposed to light.

9.3 Static Electricity

Ground soldering iron tips, tools and testers when you operate. Also ground your body when handling the products and store the products in an anti-electrostatic container.

9.4 Storage

Store the products in a dark place where the temperature is within the range of $25\pm 10^{\circ}\text{C}$ and with low humidity (60%RH or less). Do not store the LCD product in an atmosphere containing organic solvents or corrosive gases.

9.5 Cleaning

Do not wipe the polarizer with dry cloth, as it might cause scratching. Wipe the polarizer with a soft cloth soaked with petroleum IPA. Other chemical might damage the panel.



10. QC

10.1 Purpose

To ensure the stability of our product and standardize our inspection

10.2 Application Range

This standard is applied to all 3.5 inch and smaller sized LCM product from Elsun Technology Co.Ltd

10.3 Definition of inspection area

C area: The area covered after installation

B area: visible area

A area: display area

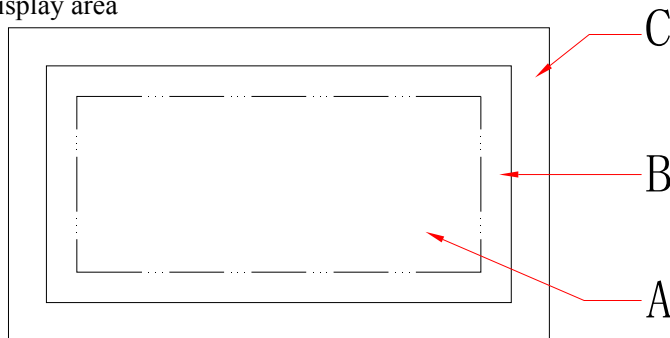

10.4 The environmental condition of inspection

Lighting conditions should be 20 ~ 40W fluorescent lamp (illumination at 1000 ± 200 lux)

Test ambient temperature should be 23 ± 5 °C, humidity at $50 \pm 20\%$ RH

The tested products should be placed 300mm away from the examiner's eye, and 30 degrees in the vertical direction observed within the region

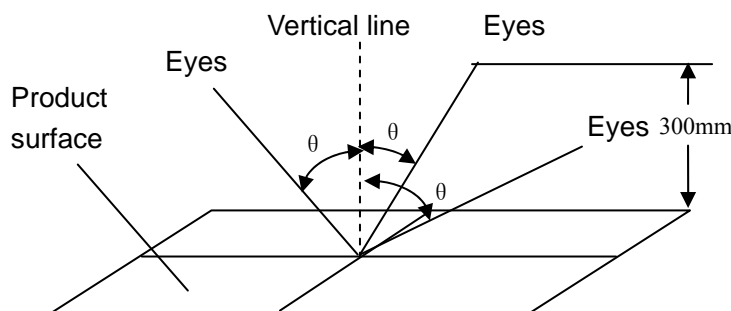

10.5 Identification

10.5.1 Bright dot: dots appearing bright and unchanged in size when the LCD panel is under black pattern.

10.5.2 Dark dot: dots appearing dark and unchanged size when the LCD panel is under RGB picture.

10.6 Inspection items and criteria



10.6.1 Serious defect

No	inspection item	inspection criteria	defect grade
10.6.1.1	function failure	1) Non-display not allowed 2) Line missing not allowed 3) Invalid touch and drift not allowed (if need)	main defect
10.6.1.2	break	broken display not allowed	main defect
10.6.1.3	dimension	Dimension tolerance out of specified in the drawing not allowed.	main defect

10.6.2 Appearance defect

No	Inspection item	inspection criteria	defect grade																				
10.6.2.1	Dot defect black dot, white dot, dirt on surface, stain, bubble	1. dot defect identification:	Minor defect																				
		2. inspection criteria range																					
		$\Phi = \frac{(\chi + \gamma)}{2}$																					
		<table border="1" style="width: 100%; border-collapse: collapse;"> <thead> <tr> <th rowspan="2">Area and quantity dimension(mm)</th> <th colspan="3">quantity allowed</th> </tr> <tr> <th>A area</th> <th>B area</th> <th>C area</th> </tr> </thead> <tbody> <tr> <td>$\Phi \leq 0.15$</td> <td colspan="2">ignore</td> <td rowspan="4" style="text-align: center; vertical-align: middle;">ignore</td> </tr> <tr> <td>$0.15 < \Phi \leq 0.2$</td> <td colspan="2">2 (spacing $\geq 10\text{mm}$)</td> </tr> <tr> <td>$0.2 < \Phi \leq 0.25$</td> <td colspan="2">1</td> </tr> <tr> <td>$\Phi > 0.25$</td> <td colspan="2">0</td> </tr> </tbody> </table>	Area and quantity dimension(mm)	quantity allowed			A area	B area	C area	$\Phi \leq 0.15$	ignore		ignore	$0.15 < \Phi \leq 0.2$	2 (spacing $\geq 10\text{mm}$)		$0.2 < \Phi \leq 0.25$	1		$\Phi > 0.25$	0		
Area and quantity dimension(mm)	quantity allowed																						
	A area	B area	C area																				
$\Phi \leq 0.15$	ignore		ignore																				
$0.15 < \Phi \leq 0.2$	2 (spacing $\geq 10\text{mm}$)																						
$0.2 < \Phi \leq 0.25$	1																						
$\Phi > 0.25$	0																						

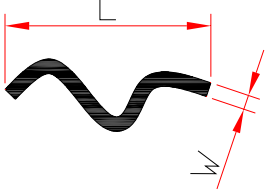

No	Inspection item	inspection criteria	defect grade																																	
10.6.2.2	line defect visible black/white line	1. identification of line dimension  L: length W: width	Minor defect																																	
		2. inspection criteria <table border="1" style="width: 100%; border-collapse: collapse;"> <thead> <tr> <th colspan="2">dimension(mm)</th> <th colspan="3">quantity allowed (total 3 pcs)</th> </tr> <tr> <th rowspan="2">L (length)</th> <th rowspan="2">W (width)</th> <th colspan="3">area</th> </tr> <tr> <th>A area</th> <th>B area</th> <th>C area</th> </tr> </thead> <tbody> <tr> <td>ignore</td> <td>$W \leq 0.03$</td> <td colspan="3">ignore</td> </tr> <tr> <td>$L \leq 3.0$</td> <td>$0.03 < W \leq 0.05$</td> <td colspan="3">2</td> </tr> <tr> <td>$L \leq 3.0$</td> <td>$0.05 < W \leq 0.08$</td> <td colspan="3">1</td> </tr> <tr> <td></td> <td>$W > 0.08$</td> <td colspan="3">count according to dot defect</td> </tr> </tbody> </table>		dimension(mm)		quantity allowed (total 3 pcs)			L (length)	W (width)	area			A area	B area	C area	ignore	$W \leq 0.03$	ignore			$L \leq 3.0$	$0.03 < W \leq 0.05$	2			$L \leq 3.0$	$0.05 < W \leq 0.08$	1				$W > 0.08$	count according to dot defect		
dimension(mm)		quantity allowed (total 3 pcs)																																		
L (length)	W (width)	area																																		
		A area	B area	C area																																
ignore	$W \leq 0.03$	ignore																																		
$L \leq 3.0$	$0.03 < W \leq 0.05$	2																																		
$L \leq 3.0$	$0.05 < W \leq 0.08$	1																																		
	$W > 0.08$	count according to dot defect																																		
10.6.2.3	scratch	1-If the scratch is visible after installation or at work, refer to 10.6.2.2 2-If the scratch is visible at special angel or at non-working status, refer to the following standards <table border="1" style="width: 100%; border-collapse: collapse;"> <thead> <tr> <th colspan="2">dimension (mm)</th> <th colspan="3">Quantity allowed</th> </tr> <tr> <th rowspan="2">L (length)</th> <th rowspan="2">W (width)</th> <th colspan="3">area</th> </tr> <tr> <th>A</th> <th>B</th> <th>C</th> </tr> </thead> <tbody> <tr> <td>ignore</td> <td>$W \leq 0.03$</td> <td colspan="3">ignore</td> </tr> <tr> <td>$5.0 < L \leq 10.0$</td> <td>$0.03 < W \leq 0.05$</td> <td colspan="3">2</td> </tr> <tr> <td>$L \leq 5.0$</td> <td>$0.05 < W \leq 0.08$</td> <td colspan="3">1</td> </tr> <tr> <td></td> <td>$W > 0.08$</td> <td colspan="3">Not allowed</td> </tr> </tbody> </table>	dimension (mm)		Quantity allowed			L (length)	W (width)	area			A	B	C	ignore	$W \leq 0.03$	ignore			$5.0 < L \leq 10.0$	$0.03 < W \leq 0.05$	2			$L \leq 5.0$	$0.05 < W \leq 0.08$	1				$W > 0.08$	Not allowed			Minor defect
dimension (mm)		Quantity allowed																																		
L (length)	W (width)	area																																		
		A	B	C																																
ignore	$W \leq 0.03$	ignore																																		
$5.0 < L \leq 10.0$	$0.03 < W \leq 0.05$	2																																		
$L \leq 5.0$	$0.05 < W \leq 0.08$	1																																		
	$W > 0.08$	Not allowed																																		

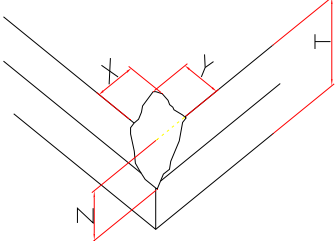
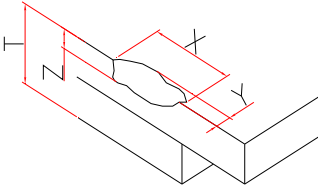
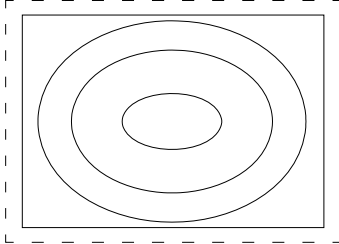
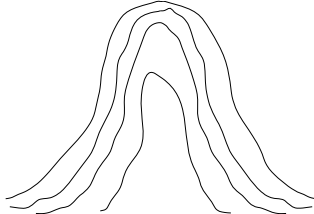

No	Inspection item	inspection criteria	defect grade
10.6.2.4	Glass defect	<p>1. broken angle</p> <p>X 不计 Y ≤ 2.0mm or X ≤ 2.0mm Y 不计 Meanwhile Z < T ignore</p>  <p>2. other broken part</p> <p>X ≤ 5.0mm Y ≤ 0.8mm Meanwhile Z ≤ T ignore</p> 	Minor defect
10.6.2.5	Newton ring	<p>1.regular Newton ring</p>  <p>① Newton ring area > 1/3 T/P area; not acceptable. ② Newton ring area ≤ 1/3 T/P area and doesn't affect the display result and no line distortion; acceptable</p> <p>2. Non-regular Newton ring</p>  <p>① Newton ring area > 1/2 T/P area, or no matter how big as long as it affects the display result; not acceptable Newton ring area ≤ 1/2 T/P area, and doesn't affect the display result and without line distortion; acceptable</p>	Minor defect



NO	Inspection item	inspection criteria	defect grade
10.6.2.6	FPC	<ol style="list-style-type: none"> 1. copper foil off, warping, crack and oxidation are not allowed 2. FPC crack, break, serious scratch and crease are not allowed 	main defect
		<ol style="list-style-type: none"> 3. if no special requirements, no release paper on double-sided adhesive FPC is not allowed. 4. Slight creases and scratches not exposed from the copper foil and with no affect to appearance and function are allowed. 5. if no special requirements, no insulating tape at welding part on backlight and touch-screen is not allowed.. 6. Parts off, breakage and deform are not allowed. 7. print on the surface should be clear and correct. 	Minor defect
10.6.2.7	basic appearance requirements	<ol style="list-style-type: none"> 1. clean appearance, no dirt, fingerprints and other traces. 2. ITO circuit on COG coating area should not be exposed. 3. Rust, sever scratch, deformation, obvious burrs and color dirt are not allowed. 4. Mis-assembly, part missing are not allowed. 5. Bubble caused by mis-pasted polaroid refers to 10.6.2.1 6. For watermark, the criteria is upon agreed by both parties. 	Minor defect



10.6.3 electric defect

No	Inspection item	inspection criteria	defect grade
10.6.3.1	picture defect	Non-display, more or less image and display defect are not allowed.	main defect
10.6.3.2	bright/dark line	Not allowed.	main defect
10.6.3.3	display dot defect	1. one dot is acceptable. 2. Under bright status, 2 dark dots with more than 5mm distance is allowed. 3. Totally 2 bright or dark dots are acceptable. 4. The other defect under bright status refers to 10.6.2.1 Note: Electric bright/dark dot means one pixel; less than 1/2 of 1 pixel can be ignored.	Minor defect
10.6.3.4	connected dot/line defect	1. Two continuous defect pixel connected dots are not allowed. 2. Line defect refers to 10.6.2.2	Minor defect
10.6.3.5	wrong view direction	Wrong view directions, such as opposite view angle, are not allowed.	main defect
10.6.3.6	back light defect	1. Backlight off are not allowed. 2. Uneven light, dead light, flicker light, dark angle, light leakage are not allowed. 3. Brightness should comply with drawing	main defect