



SPECIFICATION

Product Model: PV034600RJ30A

Approval by Customer:

Ok

NG, Problem survey

Approved By _____



Table of Contents

1	General Description.....	4
2	Module Parameter.....	4
3	Mechanical Drawings.....	5
4	Module Interface.....	6
5	Application Circuit.....	7
6	Absolute Maximum Ratings.....	7
7	Electrical Specification.....	7
8	AC Characteristics.....	8
9	Command Table.....	8
10	Recommended Setting and Initialization Flow for Reference.....	8
11	Optical Specifications.....	8
11.1	Optical Specifications.....	8
11.2	Definition of Response Time.....	9
11.3	Definition of Contrast Ratio.....	9
11.4	Definition of Viewing Angles.....	10
11.5	Definition of Color Appearance.....	10
11.6	Definition of Surface Luminance, Uniformity and Transmittance.....	10
12	Quality Assurance.....	11
12.1	Purpose.....	11
12.2	Agreement Items.....	11
12.3	Standard of the Product Visual Inspection.....	11
12.4	Inspection Specification.....	12
12.5	Classification of Defects.....	16
12.6	Identification/marketing criteria.....	16
12.7	Packing.....	16
13	Reliability Specification.....	16
14	Precautions and Warranty.....	17
14.1	Safety.....	17
14.2	Handling.....	17
14.3	Operation.....	18
14.4	Static Electricity.....	18
14.5	Limited Warranty.....	18
15	Packaging.....	18
16	Prior Consult Matter.....	18



1 General Description

This display module is a transmissive type color active matrix TFT(Thin Film Transistor) liquid crystal display (LCD) that uses amorphous silicon TFT as a switching device. This module is composed of a TFT LCD module, a driver circuit, and a back-light unit. The resolution of a 3.46" contains 340(RGB)X800 dots and can display up to 16.7M colors.

2 Module Parameter

Features	Details	Unit
Display Size(Diagonal)	3.46	inch
LCD type	α -Si TFT	-
Display Mode	IPS / Transmissive / Normally Black	-
Resolution	340RGB x 800	-
View Direction	All	Best image
Module Outline	37.27(H) × 89(V) × 1.6 (T) (Note 1)	mm
TP Outline(assembly)	N/A	mm
TP Viewing Area	N/A	mm
TP Active Area	N/A	mm
Active Area	33.97 (H) × 81 (V)	mm
Viewing Area	N/A	mm
Display Colors	16.7M	-
Interface	mipi	-
Driver IC	ST7701S	-
Operating Temperature	-20~70	°C
Storage Temperature	-30~80	°C
Weight	TBD	g

Note 1: Excluding hooks, posts , FPC/FPC tail etc.



4 Module Interface

NO	SYMBOL	FUNCTION
1-2	NC	NC
3	GND	Power Ground
4-5	NC	NC
6	GND	Power Ground
7	DP1	MIPI Data Lane
8	DN1	MIPI Data Lane
9	GND	Power Ground
10	DP0	MIPI Data Lane
11	DN0	MIPI Data Lane
12	GND	Power Ground
13	TCP	MIPI Clk
14	TCN	MIPI Clk
15	GND	Power Ground
16	RESET	This signal will reset the device and it must be applied to properly initialize the chip. Signal is active low.
17	TE	Tearing effect signal is used to synchronize MCU to frame memory writing.
18-19	LEDK	LED Cathode
20-21	LEDA	LED Anode
22	VDD	Power Supply for Analog, VDD=2.4V~3.3V.
23	VDDIO	Power Supply for I/O system. VDDIO=1.65V~3.3V
24	TP-SDA	I ² C data signal of Touch Panel; If no used, let this pin open.
25	TP-SCL	I ² C clock signal of Touch Panel; If no used, let this pin open.
26	TP-INT	Interrupt signal to main processor of Touch Panel; If no used, let this pin open.
27	TP-VDD	Analog power supply of Touch Panel. If no used, let this pin open.
28	NC	NC
29	TP-RESET	System reset of Touch Panel; If no used, let this pin open.
30	GND	Power Ground



5 Application Circuit

Backlight recommended circuit

Motherboard driver backlight is need constant current circuit:

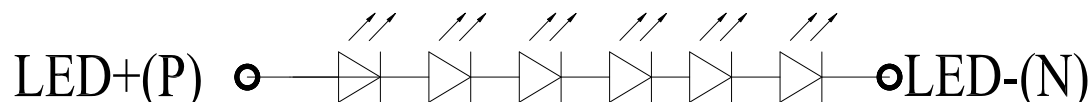

Note: constant current circuit for every LED, and though LED lamp current is less than 20mA. Recommend between 15mA and 20 mA for every LED.

6 Absolute Maximum Ratings

VSS=0V, Ta=25°C

Item		Symbol	Min.	Max.	Unit
Supply Voltage	Power supply	VDD	-0.3	+4.6	V
	Analog	-	-	-	V
	IO	IOVDD	-0.3	+4.6	V
Input Voltage		V _i	-0.3	IOVDD+0.3	V
Storage temperature		T _{stg}	-30	+80	°C
Operating temperature		T _{op}	-20	+70	°C
Storage humidity		H _{stg}	10	Note 1	%RH
Operating humidity		H _{op}	10	Note 1	%RH

Note 1: 90%RH max, If Ta is below 50°C; 60%RH max, If Ta is over 60°C.

7 Electrical Specification

DC Characteristics

Item		Symbol	Min.	Typ.	Max.	Unit
Supply Voltage	Power supply	VDD	2.4	2.8	3.3	V
	Analog	VCI	2.4	2.8	3.3	V
	IO	IOVDD	1.65	1.8/2.8	3.3	V
Logic Low input voltage		V _{IL}	-0.3IOVDD	-	0.3IOVDD	V
Logic High input voltage		V _{IH}	0.7IOVDD	-	IOVDD	V
Logic Low output voltage		V _{OL}	-	-	0.2IOVDD	V
Logic High output voltage		V _{OH}	0.8IOVDD	-	-	V
Current Consumption	Normal display	I _{vdd}	-	50	-	mA
	Standby mode	I _{vdd}	-	30	-	uA
Frame Frequency		f _{FR}	-	60	-	Hz



8 AC Characteristics

Reset timing and interface timing:

Please refer to IC datasheet.

9 Command Table

Please refer to IC datasheet.

10 Recommended Setting and Initialization Flow for Reference

Please refer to attached file.

11 Optical Specifications

11.1 Optical Specifications

Ta=25°C, VDD=2.8V, TN LC+ Polarizer

	Item	Symbol	Condition	Specification			Unit	
				Min.	Typ.	Max.		
Backlight On (Transmissive Mode)	Luminance on surface($I_f=20\text{mA}$)	L_v	Normally viewing angle $\theta_x = \theta_y = 0^\circ$		350	-	cd/m ²	
	Contrast ratio	CR		-	600	-	-	
	Response time	T_R	-	10	20	ms		
		T_F	-	20	30			
	Chromaticity Transmissive	Red	X_R	-	0.614	0.644	0.674	-
			Y_R		0.290	0.320	0.350	-
		Green	X_G		0.270	0.300	0.330	-
			Y_G		0.540	0.570	0.600	-
		Blue	X_B		0.104	0.134	0.164	-
			Y_B		0.097	0.127	0.157	-
		White	X_W		0.267	0.297	0.327	-
			Y_W		0.302	0.332	0.362	-
	Viewing Angle	Horizontal	θ_{x+}	Center $CR \geq 10$	-	80	-	Deg.
			θ_{x-}		-	80	-	
		Vertical	θ_{y+}		-	80	-	
θ_{y-}			-		80	-		
	NTSC Ratio(Gamut)	-	-	-	60	-	%	



11.2 Definition of Response Time

11.2.1 Normally Black Type (Negative)

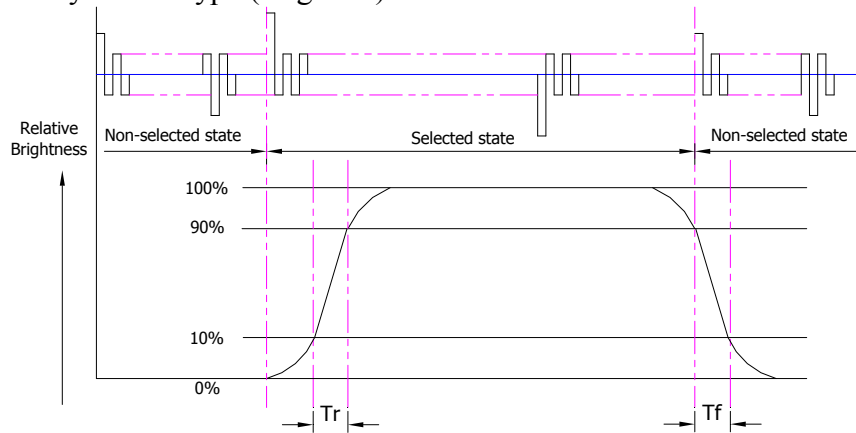

Tr is the time it takes to change form non-selected state with relative luminance 10% to selected state with relative luminance 90%;

Tf is the time it takes to change from selected state with relative luminance 90% to non-selected state with relative luminance 10%.

11.2.2 Normally White Type (Positive)

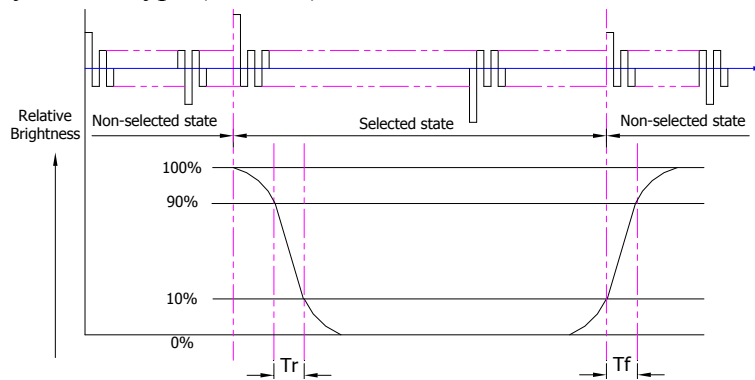

Tr is the time it takes to change form non-selected state with relative luminance 90% to selected state with relative luminance 10%;

Tf is the time it takes to change from selected state with relative luminance 10% to non-selected state with relative luminance 90%;

11.3 Definition of Contrast Ratio

Contrast is measured perpendicular to display surface in reflective and transmissive mode. The measurement condition is:

Measuring Equipment	BM-7 or EQUI
Measuring Point Diameter	3mm//1mm
Measuring Point Location	Active Area centre point
Test pattern	A: All Pixels white B: All Pixel black
Contrast setting	Maximum

Definitions: CR (Contrast) = Luminance of White Pixel / Luminance of Black Pixel



11.4 Definition of Viewing Angles

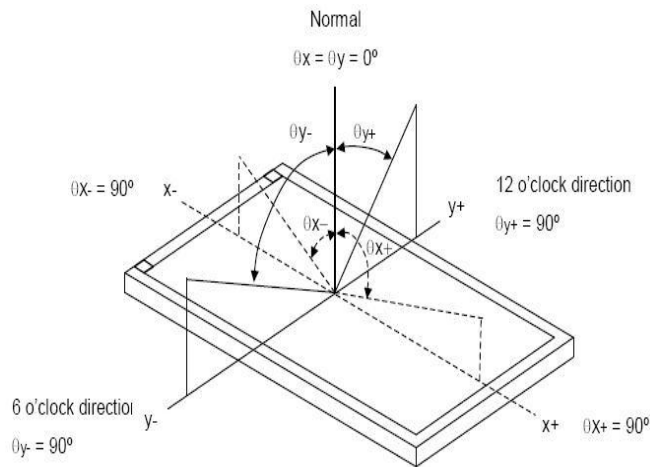

Measuring machine: LCD-5100 or EQUI

11.5 Definition of Color Appearance

R,G,B and W are defined by (x, y) on the IE chromaticity diagram

NTSC=area of RGB triangle/area of NTSC triangleX100%

Measuring picture: Red, Green, Blue and White (Measuring machine: BM-7)

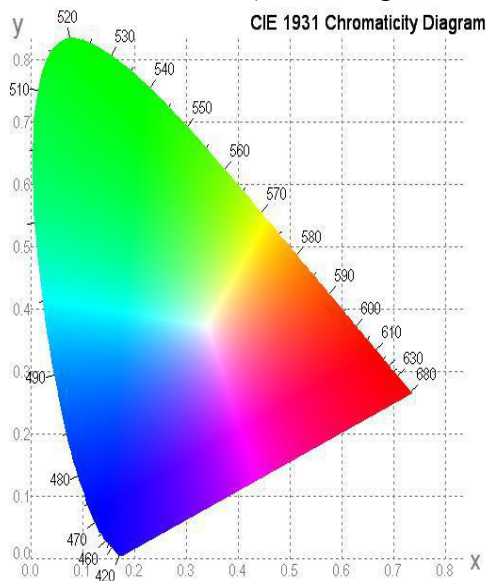

11.6 Definition of Surface Luminance, Uniformity and Transmittance

Using the transmissive mode measurement approach, measure the white screen luminance of the display panel and backlight.

11.6.1 Surface Luminance: $LV = \text{average (LP1:LP5)}$

11.6.2 Uniformity = $\text{Minimal (LP1:LP5) / Maximal (LP1:LP5) * 100\%}$

11.6.3 Transmittance = $LV \text{ on LCD} / LV \text{ on Backlight} * 100\%$

Note :Measuring machine:BM-7

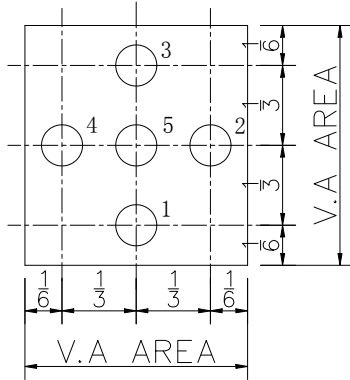

12 Quality Assurance

12.1 Purpose

This standard for Quality Assurance assures the quality of LCD module products supplied to customer by KINGTECH

12.2 Agreement Items

KINGTECH and customer shall negotiate if the following situation occurs:

12.2.1 Discrepancies between KINGTECH 's QA standards and customer's QA standards.

12.2.2 Additional requirement to be added in product specification.

12.2.3 Any other special problem.

12.3 Standard of the Product Visual Inspection

12.3.1 Appearance inspection:

12.3.1.1 The inspection must be under illumination about 1000 – 1500 lx, and the distance of view must be at 30cm ± 2cm.

12.3.1.2 The viewing angle should be 45° from the vertical line without reflection light or follows customer's viewing angle specifications.

12.3.1.3 Definition of area: A Zone: Active Area, B Zone: Viewing Area.

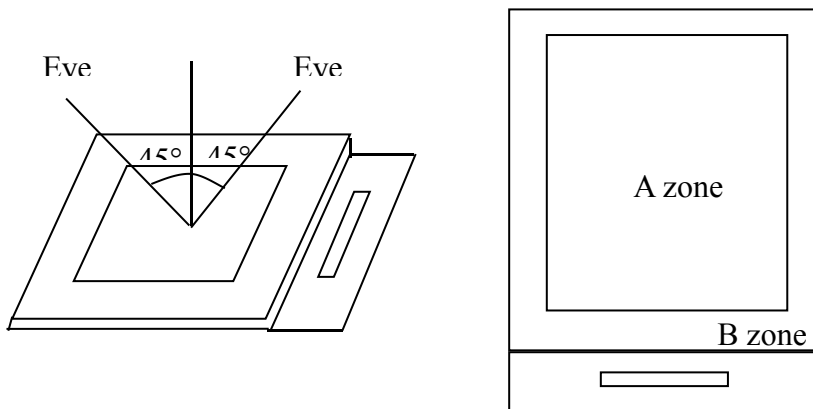

12.3.2 Basic principle: A set of sample to indicate the limit of acceptable quality level must be discussed by both KINGTECH and customer when there is any dispute happened.



12.4 Inspection Specification

Sampling plan according to GB/T2828.1-2012/ISO 2859-1: 1999 and ANSI/ASQC

Z1.4-1993,normal level 2 and based on:

Major defect: AQL 0.4

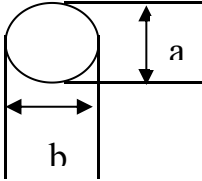
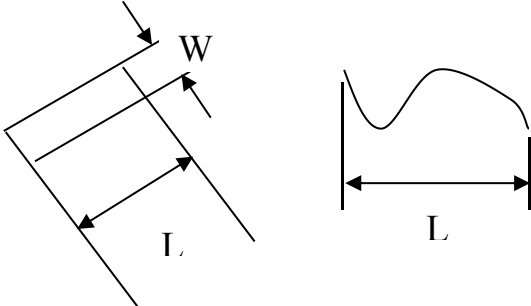

Minor defect: AQL 1.0

No.	Item	Criteria (Unit: mm)															
01	Black / White spot Foreign material (Round type) Pinholes Stain Particles inside cell. (Minor defect)	 <table border="1" data-bbox="932 667 1433 1106"> <thead> <tr> <th>Size \ Area</th> <th>Acc. Qty</th> </tr> </thead> <tbody> <tr> <td>$\phi \leq 0.10$</td> <td>Ignore</td> </tr> <tr> <td>$0.10 < \phi \leq 0.2$</td> <td>2</td> </tr> <tr> <td>$0.2 < \phi \leq 0.25$</td> <td>1</td> </tr> <tr> <td>$0.25 < \phi$</td> <td>0</td> </tr> <tr> <td>Total</td> <td>$N \leq 3$ NO include $\phi \leq 0.10$</td> </tr> </tbody> </table> <p>$\phi = (a + b) / 2$</p> <p>Distance between 2 defects should more than 10mm apart.</p>	Size \ Area	Acc. Qty	$\phi \leq 0.10$	Ignore	$0.10 < \phi \leq 0.2$	2	$0.2 < \phi \leq 0.25$	1	$0.25 < \phi$	0	Total	$N \leq 3$ NO include $\phi \leq 0.10$			
Size \ Area	Acc. Qty																
$\phi \leq 0.10$	Ignore																
$0.10 < \phi \leq 0.2$	2																
$0.2 < \phi \leq 0.25$	1																
$0.25 < \phi$	0																
Total	$N \leq 3$ NO include $\phi \leq 0.10$																
02	Black and White line Scratch Foreign material (Line type) (Minor defect)	 <table border="1" data-bbox="651 1541 1279 1832"> <thead> <tr> <th>Length</th> <th>Width</th> <th>Acc. Qty</th> </tr> </thead> <tbody> <tr> <td>/</td> <td>$W \leq 0.03$</td> <td>Ignore</td> </tr> <tr> <td>$L \leq 3$</td> <td>$0.05 < W \leq 0.08$</td> <td>2</td> </tr> <tr> <td>/</td> <td>$0.08 < W$</td> <td>0</td> </tr> <tr> <td colspan="2">Total</td> <td>$N \leq 2$</td> </tr> </tbody> </table> <p>Distance between 2 defects should more than 10mm apart. Scratches not viewable through the back of the display are acceptable.</p>	Length	Width	Acc. Qty	/	$W \leq 0.03$	Ignore	$L \leq 3$	$0.05 < W \leq 0.08$	2	/	$0.08 < W$	0	Total		$N \leq 2$
Length	Width	Acc. Qty															
/	$W \leq 0.03$	Ignore															
$L \leq 3$	$0.05 < W \leq 0.08$	2															
/	$0.08 < W$	0															
Total		$N \leq 2$															

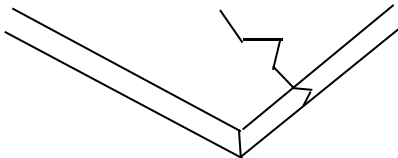
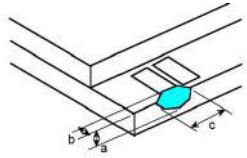
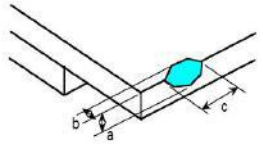
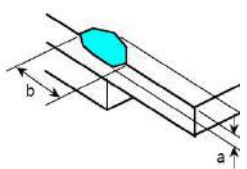

No.	Item	Criteria (Unit: mm)										
03	Glass Crack (Minor defect)	 <p>LCD with extensible crack line is unacceptable(When press the cracked LCD area, the line will expand, we define it is extensible crack line)</p>										
04	Glass Chipping Pad Area: (Minor defect)	 <table border="1" data-bbox="778 817 1248 918"> <thead> <tr> <th>Length and Width</th> <th>Acc. Qty</th> </tr> </thead> <tbody> <tr> <td>$c < 5.0, b < 0.4$</td> <td>Ignore</td> </tr> </tbody> </table>	Length and Width	Acc. Qty	$c < 5.0, b < 0.4$	Ignore						
Length and Width	Acc. Qty											
$c < 5.0, b < 0.4$	Ignore											
05	Glass Chipping Rear of Pad Area: (Minor defect)	 <table border="1" data-bbox="778 1131 1248 1377"> <thead> <tr> <th>Length and Width</th> <th>Acc. Qty</th> </tr> </thead> <tbody> <tr> <td>$c > 3.0, b < 1.0$</td> <td>1</td> </tr> <tr> <td>$c < 3.0, b < 1.0$</td> <td>2</td> </tr> <tr> <td>$c < 3.0, b < 0.5$</td> <td>4</td> </tr> <tr> <td colspan="2" style="text-align: center;">$a < \text{Glass Thickness}$</td> </tr> </tbody> </table>	Length and Width	Acc. Qty	$c > 3.0, b < 1.0$	1	$c < 3.0, b < 1.0$	2	$c < 3.0, b < 0.5$	4	$a < \text{Glass Thickness}$	
Length and Width	Acc. Qty											
$c > 3.0, b < 1.0$	1											
$c < 3.0, b < 1.0$	2											
$c < 3.0, b < 0.5$	4											
$a < \text{Glass Thickness}$												
06	Glass Chipping Except Pad Area: (Minor defect)	 <table border="1" data-bbox="778 1635 1248 1832"> <thead> <tr> <th>Length and Width</th> <th>Acc. Qty</th> </tr> </thead> <tbody> <tr> <td>$c \leq 0.6, b < 5.0$</td> <td>Ignore</td> </tr> <tr> <td colspan="2" style="text-align: center;">$a < \text{Glass Thickness}$</td> </tr> </tbody> </table>	Length and Width	Acc. Qty	$c \leq 0.6, b < 5.0$	Ignore	$a < \text{Glass Thickness}$					
Length and Width	Acc. Qty											
$c \leq 0.6, b < 5.0$	Ignore											
$a < \text{Glass Thickness}$												

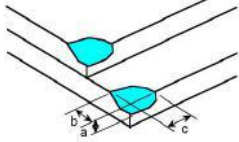
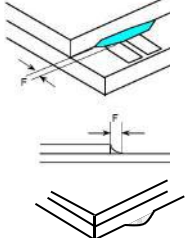
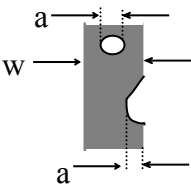

No.	Item	Criteria (Unit: mm)										
07	Glass Corner Chipping: (Minor defect) 	<table border="1" style="margin-left: auto; margin-right: auto;"> <tr> <th>Length and Width</th> <th>Acc. Qty</th> </tr> <tr> <td>$c < 2.0, b < 1.5$</td> <td>Ignore</td> </tr> <tr> <td>$c < 1.5, b < 2$</td> <td>Ignore</td> </tr> <tr> <td colspan="2" style="text-align: center;">$a < \text{Glass Thickness}$</td> </tr> </table>	Length and Width	Acc. Qty	$c < 2.0, b < 1.5$	Ignore	$c < 1.5, b < 2$	Ignore	$a < \text{Glass Thickness}$			
Length and Width	Acc. Qty											
$c < 2.0, b < 1.5$	Ignore											
$c < 1.5, b < 2$	Ignore											
$a < \text{Glass Thickness}$												
08	Glass Burr: (Minor defect) 	Glass burr don't affect assemble and module dimension. <table border="1" style="margin-left: auto; margin-right: auto;"> <tr> <th>Length</th> <th>Acc. Qty</th> </tr> <tr> <td>$F < 0.5$</td> <td>Ignore</td> </tr> </table>	Length	Acc. Qty	$F < 0.5$	Ignore						
Length	Acc. Qty											
$F < 0.5$	Ignore											
09	FPC Defect: (Minor defect) 	9.1 Dent, pinhole width $a < w/3$. (w: circuitry width.) 9.2 Open circuit is unacceptable. 9.3 No oxidation, contamination and distortion.										
10	Screen deformation 	Test for insertion of plug gauge at highest warping point: (3.1-6.0inches) $H \leq 0.3\text{MM}$ The client has special requirements, according to drawing										
11	Bubble on Polarizer (Minor defect)	<table border="1" style="margin-left: auto; margin-right: auto;"> <tr> <th>Diameter</th> <th>Acc. Qty</th> </tr> <tr> <td>$\varphi \leq 0.15$</td> <td>Ignore</td> </tr> <tr> <td>$0.15 < \varphi \leq 0.25$</td> <td>2</td> </tr> <tr> <td>$0.25 < \varphi \leq 0.3$</td> <td>1</td> </tr> <tr> <td>$0.3 < \varphi$</td> <td>0</td> </tr> </table>	Diameter	Acc. Qty	$\varphi \leq 0.15$	Ignore	$0.15 < \varphi \leq 0.25$	2	$0.25 < \varphi \leq 0.3$	1	$0.3 < \varphi$	0
Diameter	Acc. Qty											
$\varphi \leq 0.15$	Ignore											
$0.15 < \varphi \leq 0.25$	2											
$0.25 < \varphi \leq 0.3$	1											
$0.3 < \varphi$	0											



No.	Item	Criteria (Unit: mm)										
12	Dent on Polarizer (Minor defect)	<table border="1"> <thead> <tr> <th data-bbox="783 360 1066 409">Diameter</th> <th data-bbox="1066 360 1252 409">Acc. Qty</th> </tr> </thead> <tbody> <tr> <td data-bbox="783 409 1066 459">$\varphi \leq 0.15$</td> <td data-bbox="1066 409 1252 459">Ignore</td> </tr> <tr> <td data-bbox="783 459 1066 508">$0.15 < \varphi \leq 0.25$</td> <td data-bbox="1066 459 1252 508">2</td> </tr> <tr> <td data-bbox="783 508 1066 557">$0.25 < \varphi \leq 0.30$</td> <td data-bbox="1066 508 1252 557">1</td> </tr> <tr> <td data-bbox="783 557 1066 607">$0.3 < \varphi$</td> <td data-bbox="1066 557 1252 607">0</td> </tr> </tbody> </table>	Diameter	Acc. Qty	$\varphi \leq 0.15$	Ignore	$0.15 < \varphi \leq 0.25$	2	$0.25 < \varphi \leq 0.30$	1	$0.3 < \varphi$	0
Diameter	Acc. Qty											
$\varphi \leq 0.15$	Ignore											
$0.15 < \varphi \leq 0.25$	2											
$0.25 < \varphi \leq 0.30$	1											
$0.3 < \varphi$	0											
13	Bezel	13.1 No rust, distortion on the Bezel.										
14	Touch Panel	<p>D: Diameter W: width L: length</p> <p>14.1 Spot: $D \leq 0.20$ is acceptable $0.20 < D \leq 0.3$, acceptable QTY, 3 $D > 0.3$ is unacceptable</p> <p>14.2 Dent (dot): $D \leq 0.20$ is acceptable $0.20 < D \leq 0.3$, acceptable QTY, 3 $D > 0.30$ is unacceptable 2dots are acceptable and the distance between defects should more than 10 mm.</p> <p>Dent (line) According to the limit sample</p> <p>14.3 Scratch: $W \leq 0.03$, $L \leq 10$ is acceptable, $0.03 < W \leq 0.10$, $L \leq 10$, acceptable QTY, 3 $W > 0.10$ is unacceptable. Distance between 2 defects should more than 10 mm.</p>										
15	PCB	<p>15.1 No distortion or contamination on PCB terminals.</p> <p>15.2 All components on PCB must same as documented on the BOM/component layout.</p> <p>15.3 Follow IPC-A-600F.</p>										
16	Soldering	Follow IPC-A-610C standard										



No.	Item	Criteria (Unit: mm)
17	Electrical Defect (Major defect)	The below defects must be rejected. 17.1 Missing vertical / horizontal segment, 17.2 Abnormal Display. 17.3 No function or no display. 17.4 Current exceeds product specifications. 17.5 LCD viewing angle defect. 17.6 No Backlight. 17.7 Dark Backlight. 17.8 Touch Panel no function. 17.9 Dark Dot –one Allowed. 17.10 Bright Dot – one Allowed. Remark: 1. A pixel defect is acceptable if one color is none functional and causes a bright dot. The display may have one case where one color is out and cause a dark dot. 2. Bright dot caused by scratch and foreign object accords to item1.
18	Light leak	Yellow light OK; White light,According to the limit sample

Remark: Visual and cosmetic defects are rejectable only if these fall within the LCD viewing area.

12.5 Classification of Defects

Visual defects (Except no / wrong label) are treated as minor defect and electrical defect is major.

12.6 Identification/marketing criteria

Any unit with illegible / wrong /double or no marking/ label shall be rejected.

12.7 Packing

12.7.1 There should be no damage of the outside carton box, each packaging box should has label in the correct location per packing drawing requirement.

12.7.2 All direct package materials shall offer ESD protection.

13 Reliability Specification

Item	Condition	Cycle Time	Quantity	Remark
Constant Temp. and Constant Humidity Operation Test	+40 ± 3°C,90 ± 3%RH	96hrs	--	*1
High Temp. Operation Test	+70 ± 3°C	96hrs	--	
Low Temp. Operation Test	-20 ± 3°C	96hrs	--	



Thermal Shock Test	-20 ± 3°C (30min) +70 ± 3°C (30min)	10cycles	--	
ESD Test(end product)	150pF, 330Ω, ±2KV, Contact	10times	--	*2, *3
	150pF, 330Ω, ±6KV, Air			
Vibration Test (for packaging)	Frequency: 10Hz to 55Hz to10Hz,Swing:1.5mm,time: X,Y,Z each 2H.	6hrs	One inner carton	*4

Note 1. For humidity test, DI water should be used.

Inspection Standard: Inspect after 1-2hrs storage at room temperature, the sample shall be free from the following defects:

- Air bubble in the LCD
- Seal Leakage
- Non-display
- Missing Segment
- Glass Crack
- IDD is greater than twice initial value.
- Others as per QA Inspection Criteria

Note 2. No defect is allowed after testing

The End Product ESD value is only indicative and depends on customer ESD protection design for the whole system.

Note 3. ESD should be applied to LCD glass panel, not other areas (such as on IC and so on) IDD should be within twice initial value.

In case of malfunction defect caused by ESD damage, if it would be recovered to normal state after resetting, it would be judged as a good part.

Note 4. Only upon request.

14 Precautions and Warranty

14.1 Safety

14.1.1 The liquid crystal in the LCD is poisonous. Do not put it in your mouth. If the liquid crystal touches your skin or clothes, wash it off immediately using soap and water.

14.1.2 Since the liquid crystal cells are made of glass, do not apply strong impact on them.

Handle with care.

14.2 Handling

14.2.1 Reverse and use within ratings in order to keep performance and prevent damage.

14.2.2 Do not wipe the polarizer with dry cloth, as it might cause scratch. If the surface of the



LCD needs to be cleaned, wipe it swiftly with cotton or other soft cloth soaked with petroleum IPA, do not use other chemicals.

14.3 Operation

14.3.1 Do not drive LCD with DC voltage

14.3.2 Response time will increase below lower temperature

14.3.3 Display may change color with different temperature

14.3.4 Mechanical disturbance during operation, such as pressing on the display area, may cause the segments to appear “fractured”.

14.4 Static Electricity

14.4.1 CMOS LSIs are equipped in this unit, so care must be taken to avoid the electro-static charge, by ground human body, etc.

14.4.2 The normal static prevention measures should be observed for work clothes and benches.

14.4.3 The module should be kept into anti-static bags or other containers resistant to static for storage.

14.5 Limited Warranty

14.5.1 Unless otherwise agreed between KINGTECH and customer, KINGTECH will replace or repair any of its LCD and LCM which KINGTECH found to be defective electrically and visually when inspected in accordance with KINGTECH Quality Standards, for a period of one year from date of shipment.

14.5.2 The warranty liability of KINGTECH is limited to repair and/or replacement.

KINGTECH will not be responsible for any consequential loss.

14.5.3 If possible, we suggest you use up all modules in six months. If the module storage time over twelve months, we suggest that recheck it before the module be used.

15 Packaging

TBD

16 Prior Consult Matter

1. For KINGTECH standard products, we keep the right to change material, process for improving the product property without prior notice to our customer.

2. For OEM products, if any changes are needed which may affect the product property, we will consult with our customer in advance.

3. If you have special requirement about reliability condition, please let us know before you start the test on our samples.